

RING TYPE JOINTS

Dimensions of Class 150 Female Ring-Joint Facing Figure 8 Blanks

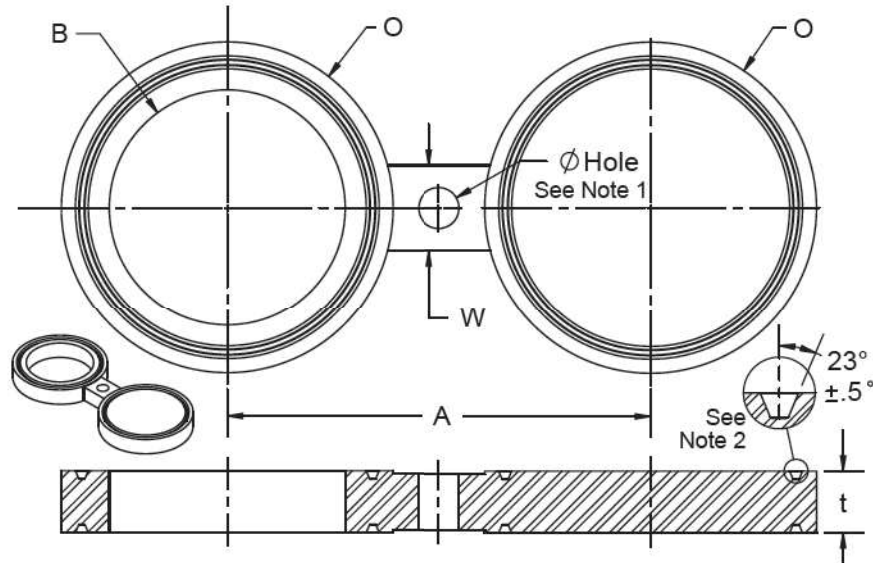

NPS	Inside Diameter <i>B</i>		Outside Diameter <i>O</i>		Centerline Dimension <i>A</i>		Thickness <i>t</i>		Web Width <i>W</i>		HOLE	WGT
	In.	mm.	In.	mm.	In.	mm.	In.	mm.	In.	mm.		
1	1.32	34	2.50	64	3.12	79	0.75	19	2.00	51	0.62	3.0
1 1/4	1.66	42	2.88	73	3.50	89	0.75	19	2.00	51	0.62	4.0
1 1/2	1.90	48	3.25	83	3.88	99	0.75	19	2.25	57	0.62	5.0
2	2.38	60	4.00	102	4.75	121	0.75	19	2.25	57	0.75	5.0
2 1/2	2.88	73	4.75	121	5.50	140	0.88	22	2.25	57	0.75	10.0
3	3.50	89	5.25	133	6.00	152	0.88	22	2.25	57	0.75	15.0
3 1/2	4.00	102	6.06	154	7.00	178	0.88	22	2.50	64	0.75	17.5
4	4.50	114	6.75	171	7.50	190	0.88	22	2.50	64	0.75	20.0
5	5.56	141	7.62	194	8.50	216	1.00	25	2.75	70	0.88	30.0
6	6.62	168	8.62	219	9.50	241	1.00	25	3.25	83	0.88	40.0
8	8.62	219	10.75	273	11.75	298	1.12	28	3.75	95	0.88	60.0
10	10.75	273	13.00	330	14.25	362	1.25	32	4.00	102	1.00	80.0
12	12.75	324	16.00	406	17.00	432	1.38	35	4.75	121	1.00	100.0
14	14.00	356	16.75	425	18.75	476	1.38	34	5.00	127	1.12	120.0
16	16.00	406	19.00	483	21.25	540	1.50	38	5.00	127	1.12	150.0
18	18.00	457	21.50	546	22.75	578	1.62	41	5.00	127	1.25	200.0
20	20.00	508	23.50	597	25.00	635	1.62	41	5.00	127	1.25	250.0
24	24.00	610	28.00	711	29.50	749	1.88	48	6.00	152	1.38	400.0

Note: 1. Hole size (where required due to bolt spacing) shall be the same as the flange bolt hole.

Note: 1. Female ring joint groove dimensions shall be designed for octagonal rings in accordance with ANSI B16.5.

RING TYPE JOINTS

Dimensions of Class 300 Female Ring-Joint Facing Figure 8 Blanks

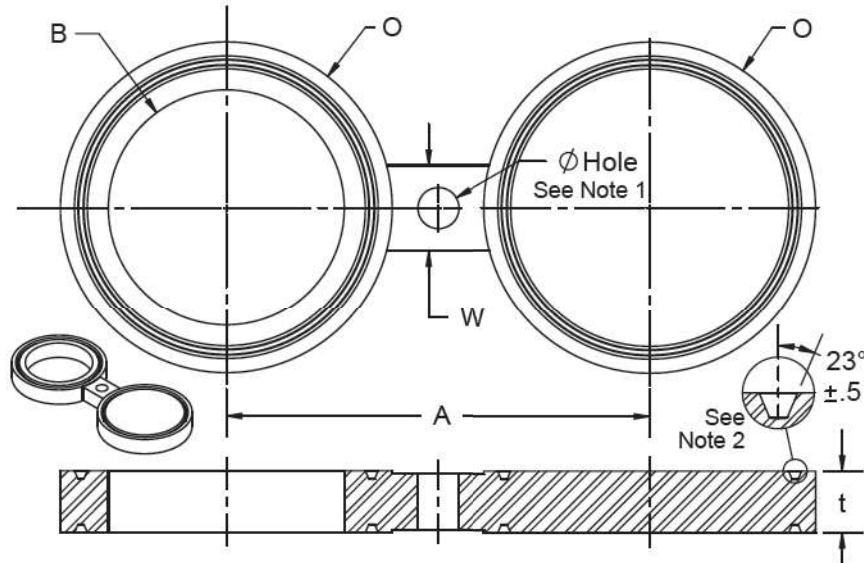

NPS	Inside Diameter <i>B</i>		Outside Diameter <i>O</i>		Centerline Dimension <i>A</i>		Thickness <i>t</i>		Web Width <i>W</i>		HOLE	WGT
	In.	mm.	In.	mm.	In.	mm.	In.	mm.	In.	mm.		
1/2	0.84	21	2.00	51	2.62	67	0.62	16	1.50	38	0.62	2.0
3/4	1.05	27	2.50	64	3.25	83	0.75	19	1.75	44	0.75	3.0
1	1.32	34	2.75	70	3.50	89	0.75	19	2.00	51	0.75	3.0
1 1/4	1.66	42	3.12	79	3.88	99	0.88	22	2.00	51	0.75	4.0
1 1/2	1.90	48	3.56	90	4.50	114	0.88	22	2.25	57	0.88	5.0
2	2.38	60	4.25	108	5.00	127	1.00	25	2.25	57	0.75	10.0
2 1/2	2.88	73	5.00	127	5.88	149	1.12	28	2.25	57	0.88	10.0
3	3.50	89	5.75	146	6.62	168	1.12	28	2.25	57	0.88	15.0
3 1/2	4.00	102	6.25	159	7.25	184	1.12	28	2.50	64	0.88	17.5
4	4.50	114	6.88	175	7.88	200	1.25	32	2.50	64	0.88	20.0
5	5.56	141	8.25	210	9.25	235	1.38	35	2.75	70	0.88	30.0
6	6.62	168	9.50	241	10.62	270	1.38	35	3.25	83	0.88	40.0
8	8.62	219	11.88	302	13.00	330	1.62	41	3.75	95	1.00	80.0
10	10.75	273	14.00	356	15.25	387	1.75	44	4.00	102	1.12	100.0
12	12.75	324	16.25	413	17.75	451	2.00	51	4.75	121	1.25	150.0
14	14.00	356	18.00	457	20.25	514	2.12	54	5.00	127	1.25	200.0
16	16.00	406	20.00	508	22.50	572	2.25	57	5.00	127	1.38	250.0
18	18.00	457	22.62	575	24.75	629	2.38	60	5.00	127	1.38	350.0
20	20.00	508	25.00	635	27.00	686	2.75	70	5.00	127	1.38	500.0
24	24.00	610	29.50	749	32.00	813	3.12	79	6.00	152	1.62	800.0

Note: 1. Hole size (where required due to bolt spacing) shall be the same as the flange bolt hole.

Note: 1. Female ring joint groove dimensions shall be designed for octagonal rings in accordance with ANSI B16.5.

RING TYPE JOINTS

Dimensions of Class 600 Female Ring-Joint Facing Figure 8 Blanks

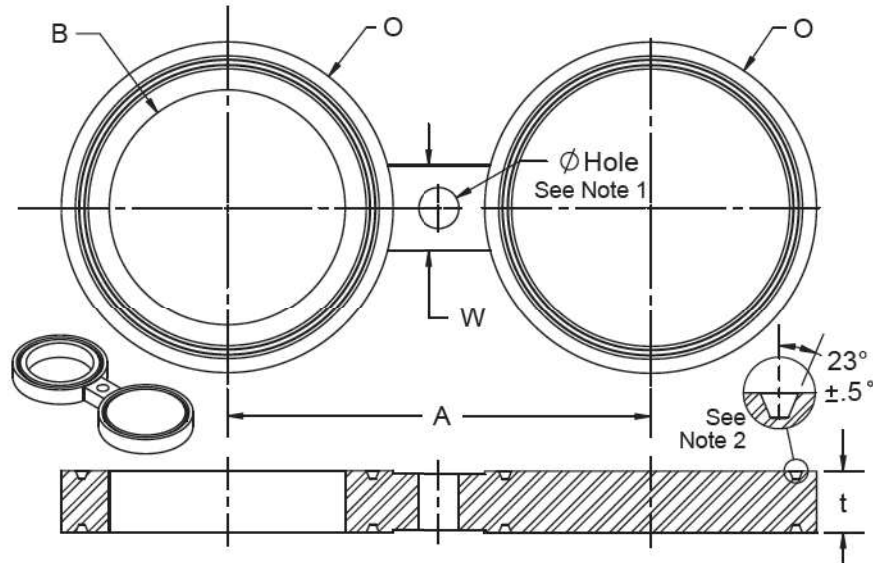

NPS	Inside Diameter <i>B</i>		Outside Diameter <i>O</i>		Centerline Dimension <i>A</i>		Thickness <i>t</i>		Web Width <i>W</i>		HOLE	WGT
	In.	mm.	In.	mm.	In.	mm.	In.	mm.	In.	mm.		
1/2	0.84	21	2.00	51	2.62	67	0.75	19	1.50	38	0.62	2.0
3/4	1.05	27	2.50	64	3.25	83	0.88	22	1.75	44	0.75	3.0
1	1.32	34	2.75	70	3.50	89	0.88	22	2.00	51	0.75	3.0
1 1/4	1.66	42	3.12	79	3.88	99	0.88	22	2.00	51	0.75	4.0
1 1/2	1.90	48	3.56	90	4.50	114	0.88	22	2.25	57	0.88	5.0
2	2.38	60	4.25	108	5.00	127	1.12	28	2.25	57	0.75	10.0
2 1/2	2.88	73	5.00	127	5.88	149	1.25	32	2.25	57	0.88	10.0
3	3.50	89	5.75	146	6.62	168	1.25	32	2.25	57	0.88	15.0
3 1/2	4.00	102	6.25	159	7.25	184	1.38	35	2.50	64	1.00	17.5
4	4.50	114	6.88	175	8.50	216	1.38	35	2.50	64	1.00	20.0
5	5.56	141	8.25	210	10.50	267	1.50	38	2.75	70	1.12	30.0
6	6.62	168	9.50	241	11.50	292	1.75	44	3.25	83	1.12	40.0
8	8.62	219	11.88	302	13.75	349	2.00	51	3.75	95	1.25	80.0
10	10.75	273	14.00	356	17.00	432	2.25	57	4.00	102	1.38	130.0
12	12.75	324	16.25	413	19.25	489	2.50	64	4.75	121	1.38	200.0
14	14.00	356	18.00	457	20.75	527	2.62	67	5.00	127	1.50	250.0
16	16.00	406	20.00	508	23.75	603	2.88	73	5.00	127	1.62	350.0
18	18.00	457	22.62	575	25.75	654	3.12	79	5.00	127	1.75	500.0
20	20.00	508	25.00	635	28.50	724	3.50	89	5.00	127	1.75	650.0
24	24.00	610	29.50	749	33.00	838	4.12	105	6.00	152	2.00	1000.0

Note: 1. Hole size (where required due to bolt spacing) shall be the same as the flange bolt hole.

Note: 1. Female ring joint groove dimensions shall be designed for octagonal rings in accordance with ANSI B16.5.

RING TYPE JOINTS

Dimensions of Class 900 Female Ring-Joint Facing Figure 8 Blanks

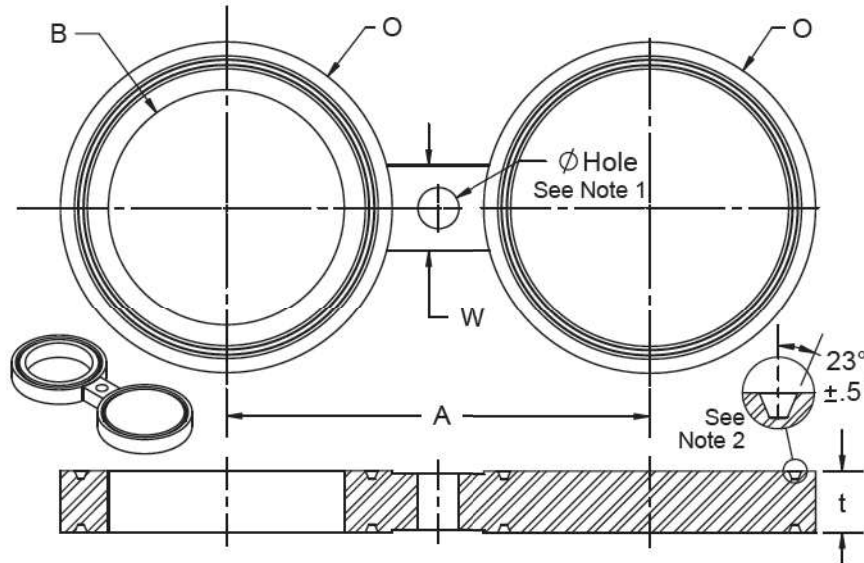

NPS	Inside Diameter <i>B</i>		Outside Diameter <i>O</i>		Centerline Dimension <i>A</i>		Thickness <i>t</i>		Web Width <i>W</i>		HOLE	WGT
	In.	mm.	In.	mm.	In.	mm.	In.	mm.	In.	mm.		
1/2	0.84	21	2.38	60	3.25	83	0.88	22	1.50	38	0.88	3.0
3/4	1.05	27	2.62	67	3.50	89	0.88	22	1.75	44	0.88	4.0
1	1.32	34	2.81	71	4.00	102	0.88	22	2.00	51	1.00	5.0
1 1/4	1.66	42	3.19	81	4.38	111	1.00	25	2.00	51	1.00	5.0
1 1/2	1.90	48	3.62	92	4.88	124	1.00	25	2.50	64	1.12	5.0
2	2.38	60	4.88	124	6.50	165	1.25	32	2.00	51	1.00	10.0
2 1/2	2.88	73	5.38	137	7.50	190	1.38	35	2.62	67	1.12	15.0
3	3.50	89	6.12	156	7.50	190	1.38	35	2.62	67	1.00	20.0
4	4.50	114	7.12	181	9.25	235	1.62	41	2.88	73	1.25	30.0
5	5.56	141	8.50	216	11.00	279	1.75	44	2.88	73	1.38	45.0
6	6.62	168	9.50	241	12.50	318	1.88	48	2.88	73	1.25	60.0
8	8.62	219	12.12	308	15.50	394	2.25	57	3.12	79	1.50	100.0
10	10.75	273	14.25	362	18.50	470	2.50	64	4.75	121	1.50	150.0
12	12.75	324	16.50	419	21.00	533	2.88	73	4.75	121	1.50	250.0
14	14.00	356	18.38	467	22.00	559	3.25	83	4.75	121	1.62	250.0
16	16.00	406	20.62	524	24.25	616	3.62	92	5.00	127	1.75	450.0
18	18.00	457	23.38	594	27.00	686	4.00	102	5.25	133	2.00	700.0
20	20.00	508	25.50	648	29.50	749	4.38	111	5.00	127	2.12	900.0
24	24.00	610	30.38	772	35.50	902	5.25	133	5.50	140	2.62	1100.0

Note: 1. Hole size (where required due to bolt spacing) shall be the same as the flange bolt hole.

Note: 1. Female ring joint groove dimensions shall be designed for octagonal rings in accordance with ANSI B16.5.

RING TYPE JOINTS

Dimensions of Class 1500 Female Ring-Joint Facing Figure 8 Blanks

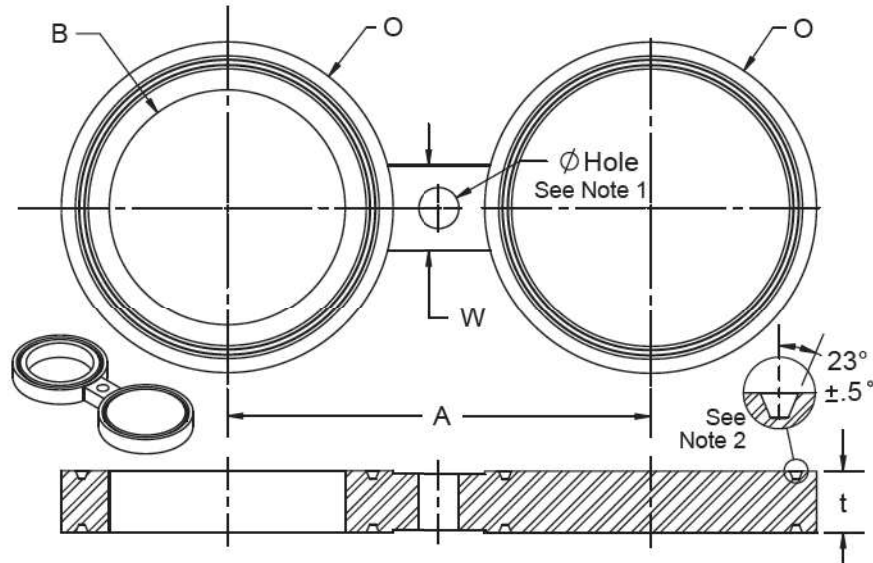

NPS	Inside Diameter <i>B</i>		Outside Diameter <i>O</i>		Centerline Dimension <i>A</i>		Thickness <i>t</i>		Web Width <i>W</i>		HOLE	WGT
	In.	mm.	In.	mm.	In.	mm.	In.	mm.	In.	mm.		
1/2	0.84	21	2.38	60	3.25	83	0.88	22	1.50	38	0.88	2.1
3/4	1.05	27	2.62	67	3.50	89	1.00	25	1.75	44	0.88	2.8
1	1.32	34	2.81	71	4.00	102	1.00	25	2.12	54	1.00	3.1
1 1/4	1.66	42	3.19	81	4.38	111	1.00	25	2.12	54	1.00	3.9
1 1/2	1.90	48	3.62	92	4.88	124	1.12	28	2.25	57	1.12	5.6
2	2.38	60	4.88	124	6.50	165	1.38	35	2.12	54	1.00	12.9
2 1/2	2.88	73	5.38	137	7.50	190	1.50	38	2.25	57	1.12	16.6
3	3.50	89	6.62	168	8.00	203	1.75	44	2.88	73	1.25	29.0
4	4.50	114	7.62	194	9.50	241	1.88	48	3.00	76	1.38	40.0
5	5.56	141	9.00	229	11.50	292	2.12	54	3.00	76	1.62	62.0
6	6.62	168	9.75	248	12.50	318	2.38	60	3.12	79	1.50	78.0
8	8.62	219	12.50	318	15.50	394	2.88	73	3.38	86	1.75	153.0
10	10.75	273	14.62	371	19.00	483	3.25	83	5.25	133	2.00	226.0
12	12.75	324	17.25	438	22.50	572	4.00	102	5.25	133	2.12	385.0
14	14.00	356	19.25	489	25.00	635	4.38	111	5.50	140	2.38	532.0
16	16.00	406	21.50	546	27.75	705	4.88	124	5.75	146	2.62	727.0
18	18.00	457	24.12	613	30.50	775	5.25	133	6.00	152	2.88	982.0
20	20.00	508	26.50	673	32.75	832	5.62	143	6.50	165	3.12	1258.0
24	24.00	610	31.25	772	39.00	991	6.62	168	7.00	179	3.62	2031.0

Note: 1. Hole size (where required due to bolt spacing) shall be the same as the flange bolt hole.

Note: 1. Female ring joint groove dimensions shall be designed for octagonal rings in accordance with ANSI B16.5.

RING TYPE JOINTS

Dimensions of Class 2500 Female Ring-Joint Facing Figure 8 Blanks

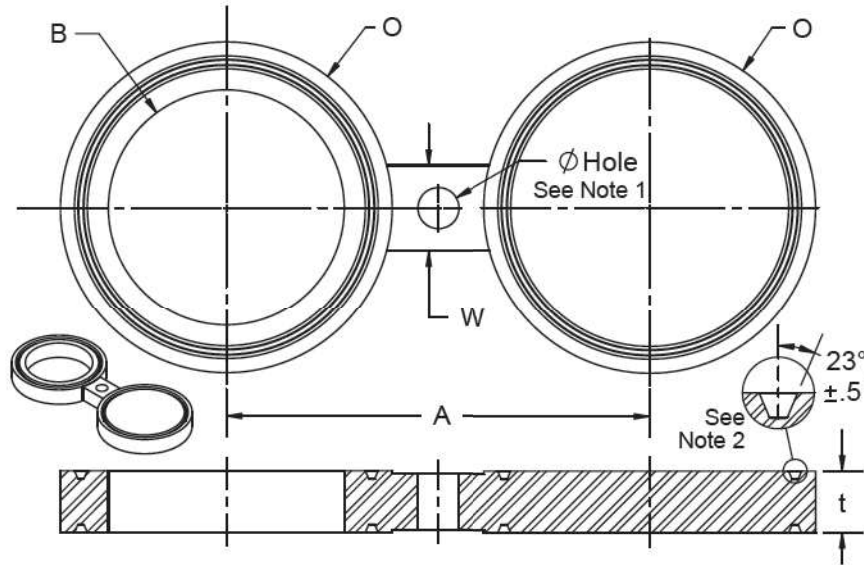

NPS	Inside Diameter <i>B</i>		Outside Diameter <i>O</i>		Centerline Dimension <i>A</i>		Thickness <i>t</i>		Web Width <i>W</i>		HOLE	WGT
	In.	mm.	In.	mm.	In.	mm.	In.	mm.	In.	mm.		
1/2	0.84	21	2.56	65	3.50	89	1.00	25	1.50	38	0.88	2.8
3/4	1.05	27	2.88	73	3.75	95	1.12	28	1.75	44	0.88	3.9
1	1.32	34	3.25	83	4.25	108	1.12	28	2.12	54	1.00	4.8
1 1/4	1.66	42	4.00	102	5.12	130	1.38	35	2.12	54	1.12	9.0
1 1/2	1.90	48	4.50	114	5.75	146	1.50	38	2.38	60	1.25	12.3
2	2.38	60	5.25	133	6.75	171	1.62	41	2.25	57	1.12	17.8
2 1/2	2.88	73	5.88	149	7.75	197	1.88	48	2.38	60	1.25	25.5
3	3.50	89	6.62	168	9.00	229	2.00	51	3.00	76	1.38	34.0
4	4.50	114	8.00	203	10.75	273	2.50	64	3.25	83	1.62	60.0
5	5.56	141	9.50	241	12.75	324	2.88	73	3.50	89	1.88	73.0
6	6.62	168	11.00	279	14.50	368	3.25	83	3.75	95	2.12	143.0
8	8.62	219	13.38	340	17.25	438	3.88	99	3.75	95	2.12	245.0
10	10.75	273	16.75	425	21.25	540	4.62	117	3.58	91	2.62	459.0
12	12.75	324	19.50	495	24.38	619	5.25	133	6.00	152	2.88	699.0

Note: 1. Hole size (where required due to bolt spacing) shall be the same as the flange bolt hole.

Note: 1. Female ring joint groove dimensions shall be designed for octagonal rings in accordance with ANSI B16.5.