



Swage Nipples

Concentric & Eccentric, all pipe schedules in any combination of end types. Available in A234-WPB, A420-WPL6, WP304, WP316 & Alloys. Sizes 1/8" to 12"

Pipe Nipples

Meet ASTM A733
ASME B36.10, B36.19 & B16.11 Requirements. Across CRN Canada. Available upon request. Available Galvanized. Size 1/8" to 4"

Bull Plugs

All schedules available. Tapped 1/2", 3/4", & 1" available. Available in A234-WPBS9, A420-WPL6, WP304, WP316 & Alloys. Size 1/8" to 12"

Oil Country Fittings

Swage Nipples & Belled Nipples

Tubing & Casing. Upset one end or both ends. Casing Non-EUE ends. Available in J55, L80, N80, P110. Sizes 1.315" to 13 3/8"

Bull Plugs

All schedules available. Tapped 1/2", 3/4", & 1" available. Available in J55, L80, N80, P110. Size 1.315" to 13 3/8"

Pump Seating Nipples

Available in API bore sizes. Available in J55, L80, N80, P110. API monogrammed. Sizes 2 3/8" to 3 1/2"

Couplings

Tubing & Casing. Available in J55, L80, N80, P110. API monogrammed. Sizes 1.315" to 13 3/8"

Pup Joints

Tubing & Casing. Available in J55, L80, N80, P110. API monogrammed. Sizes 2 3/8" to 7" OD

Spectacle Blinds/Single Blind Spacer Rings/Vent Blinds & Bleed Rings

125# to 2500# ANSI pressures. Available in A516/304/316, & Alloys. Sizes 1/2" to 84"

Orifice Plates Series 520, 500

125# to 2500# ANSI pressures. Sizes 1/2" to 84"

Pile Caps

Available in all plate sizes.

Permanent Strainers

Inline, Tee type & Y-type. 150# to 600# ANSI pressures. Threaded, Flanged, Butt Weld & Socket Weld. Sizes 1/2" to 36"

Temporary Strainers

Conical & Basket type. #150# to 2500# ANSI pressures. Sizes 1/2" to 36"

Chokes

Adjustable & Positive Bean types. Heater Chokes. Threaded, Flanged & Butt Weld.

API Flanges

2000# to 20000# API pressures. Companion, Blind, & Weld Neck API Monogrammed. Sizes 1-13/16" to 7-1/16"

Hammer Unions

Available in Standard & Sour Service. Available Threaded, Socket Weld & Butt Weld. All Sizes 1" to 12", figures & schedules.

MANUFACTURING SPECIFICATION

Kedddco manufacturers swage nipples and bull plugs in accordance with A234, A420, A403 and MSS-SP-95, from A-106 Grade B seamless pipe and A-1000 series, low to medium carbon, fine grain, cold drawn bar stock and heat treated to these specifications. The chemical and physical properties of the raw material fall within the range listed below.

TRACEABILITY

All raw material purchased by Kedddco is fully traceable to the mill source. A heat number appears on all Kedddco products made since the institution of this program. As a result, mill test reports are available at any time on products.

PRESSURE RATINGS

Due to the wide variation in service conditions, temperature, vibrations, etc., Kedddco can make no recommendations as to allowable working pressures of swage nipples and bull plugs. There are a number of working pressure formulas from which the end user may choose to determine the required wall thickness of the piping system. It is our responsibility only to furnish a fitting with end dimensions equal to those of the pipe size and schedule ordered.

MATERIAL CERTIFICATION

Kedddco certifies that the material used to manufacture line pipe sizes of swage nipples and bull plugs has been processed and heat treated to comply with all requirements of ASTM A234, A420, A403 and that the chemical and physical properties of the raw material fall within the ranges listed.

SPECIFICATION				ANALYSIS							
ASTM SPEC.	TITLE	GRADE	DESCRIPTION	CARBON	MANG.	PHOS. MAX	SULP. MAX	SILICON	NICKEL	CHR.	MO.
A 234	Carbon Steel	WPB		.30 Max.	.29-1.06	.050	.058	.10 Min	.40 Max	.40 Max	.15 Max
A 420	Carbon and Alloy Steel Fittings For Low Temperature Service	WPL 6		.30 Max.	.50-1.35	.035	.040	.15-.40	.40 Max	.30 Max	.12 Max
A 234	Ferretic Alloy Steel Fittings For High Temperature Service	WP 1	Carbon Moly	.28 Max.	.30-.90	.045	.045	.10-.5044-.65
		WP 5	4-6 Chrome 1/2 Moly	.15 Max.	.30-.60	.040	.030	.50 Max	4.00-6.00	.44-.65
		WP 9	9 Chrome 1 Moly	.15 Max.	.30-.60	.030	.030	1.00 Max	8.00-10.00	.90-1.10
		WP 11	1 1/4 Chrome 1/2 Moly	.20 Max.	.30-.80	.040	.040	.5-1.00	1.00-1.50	.44-.65
		WP 12	1 Chrome 1 Moly	.20 Max.	.30-.80	.045	.045	.60 Max80-1.25	.44-.65
		WP 22	2 1/4 Chrome 1 Moly	.15 Max.	.30-.60	.040	.040	.50 Max	1.90-2.60	.87-1.13
		WP 91		.12 Max.	.30-.60	.062	.010	.20-.50	.40 Max	8.00-9.50	.85-1.05
A 403	Austenitic Alloy Steel Fittings For Corrosive Service	WP 304	Type 304-18-8 Stainless Steel	.08 Max.	2.00 Max	.045	.030	.1.00 Max	8.00-11.00	18.0-20.0
		WP 304L	Type 304 ELC-18-8 Stainless Steel	.030 Max.	2.00 Max	.045	.030	.1.00 Max	8.00-12.00	18.0-20.0
		WP 316	Type 316-18-8 Mo Stainless Steel	.08 Max.	2.00 Max	.045	.030	.1.00 Max	10.00-14.00	16.00-18.00	2.00-3.00
		WP 316L	Type 316 ELC-18-8 Mo Stainless Steel	.030 Max.	2.00 Max	.045	.030	.1.00 Max	10.00-14.00	16.00-18.00	2.00-3.00
		WP 347	Type 347-18-8 cb Stainless Steel	.08 Max.	2.00 Max	.045	.030	.1.00 Max	9.00-13.00	17.00-19.00
		WP 321	Type 321-18-8 Ti Stainless Steel	.08 Max.	2.00 Max	.045	.030	.1.00 Max	9.00-13.00	17.00-19.00

MARKING		THREADING
All Keddco fittings are permanently marked as follows:		NPT in conformance with ANSI B1.20.1 Line pipe, tubing and casing are in conformance with API 5B
Manufacturer's Symbol		COATINGS Zinc Electroplate – ASTM A164 Type RS Phosphate – Beveled Ends Hot-Dip Galv – ASTM A123
Material Specification	WPB, WPL6, WP304, WP316 (Alloys) J55, N80, L80, P110, 4130, 4140	
Raw Material Code	Each part is die stamped with a unique heat code identifying the raw material type, details of purchase and steel mill test report.	WELD BEVELS Weld Bevels are machined as per ASME B-16.9
Heat Treatment	When marked WPB, WPL6, an acceptable heat treatment is understood to have been performed.	
Label Information	Size and Wall Thickness.	

SWAGE NIPPLES

- Nominal Pipe size range 1/8 NPS / 6 DN – 12 NPS / 200 DN.
- Choice of raw material dependant upon size and reduction.
- Available standard, extra heavy, schedule 160, or double extra heavy.
- End finishes available: current API threads or ANSI, beveled, square cut (for socket-weld), or grooved.
- Available concentric and eccentric.

SIZE													
PIPE		API or O.D.		REDUCED TO		LENGTH		STANDARD WEIGHT		EXTRA HEAVY WEIGHT		DBL EX. & 160 WEIGHT	
NPS	DN	IN	MM	NPS	DN	IN	MM	LB	KG	LB	KG	LB	KG
1/4	8	.540	15	1/8	6	2-1/4	57					.25	.11
3/8	10	.675	15	1/8	6	2-1/2	63			.25	.11	.38	.17
				1/4	8	2-1/2	63			.25	.11	.38	.17
1/2	15	.840	20	1/8	6	2-3/4	70			.33	.15	.50	.23
				1/4 & 3/8	8 & 10	2-3/4	70			.33	.15	.50	.23
3/4	20	1.050	25	1/8	6	3	76			.50	.23	.75	.34
				1/4 & 3/8	8 & 10	3	76			.50	.23	.75	.34
				1/2	15	3	76			.50	.23	.75	.34
1	25	1.315	33	1/8	6	3-1/2	88			.66	.30	1.00	.45
				1/4 & 3/8	8 & 10	3-1/2	88			.66	.30	1.00	.45
				1/2 & 3/4	15 & 20	3-1/2	88			.66	.30	1.00	.45
1-1/4	32	1.660	42	1/4 & 3/8	8 & 10	4	102			1.00	.45	1.50	.68
				1/2 & 3/4	15 & 20	4	102			1.00	.45	1.50	.68
				1	25	4	102			1.00	.45	1.50	.68
				1-1/4	32	4	102			1.00	.45	1.50	.68
1-1/2	40	1.900	48	1/4 & 3/8	8 & 10	4-1/2	114			1.17	.53	2.00	.91
				1/2 & 3/4	15 & 20	4-1/2	114			1.17	.53	2.00	.91
				1	25	4-1/2	114			1.17	.53	2.00	.91
				1-1/4	32	4-1/2	114			1.17	.53	2.00	.91
2	50	2-3/8	60	1/4 & 3/8	8 & 10	6-1/2	165			3.00	1.36	4.25	1.93
				1/2 & 3/4	15 & 20	6-1/2	165			3.00	1.36	4.25	1.93
				1	25	6-1/2	165	2.00	.90	2.33	1.06	4.25	1.93
				1-1/4	32	6-1/2	165	2.00	.90	2.33	1.06	4.25	1.93
				1-1/2	40	6-1/2	165	2.00	.90	2.33	1.06	4.25	1.93
2-1/2	65	2-7/8	73	1/2 & 3/4	15 & 20	7	178			3.50	1.60	8.00	3.64
				1	25	7	178	3.00	1.36	3.50	1.60	8.00	3.64
				1-1/4	32	7	178	3.00	1.36	3.50	1.60	8.00	3.64
				1-1/2	40	7	178	3.00	1.36	3.50	1.60	8.00	3.64
				2	50	7	178	3.00	1.36	3.50	1.60	8.00	3.64
3	80	3-1/2	88	1/2 & 3/4	15 & 20	8	203			6.00	2.73	11.00	5.00
				1	25	8	203	4.50	2.00	6.00	2.73	11.00	5.00
				1-1/4	32	8	203	4.50	2.00	6.00	2.73	11.00	5.00
				1-1/2	40	8	203	4.50	2.00	6.00	2.73	11.00	5.00
				2 & 2-1/2	50 & 65	8	203	4.50	2.00	6.00	2.73	11.00	5.00
3-1/2	90	4	100	1/2 thru 1-1/2	15 thru 40	8	203	5.50	2.50	7.50	3.40	13.50	6.14
				2 thru 3	50 thru 80	8	203	5.50	2.50	7.50	3.40	13.50	6.14
4	100	4-1/2	114	1/2 & 3/4	15 & 20	9	229			10.00	4.50	18.00	8.20
				1	25	9	229	7.50	3.40	10.00	4.50	18.00	8.20
				1-1/4 & 1-1/2	32 & 40	9	229	7.50	3.40	10.00	4.50	18.00	8.20
				2	50	9	229	7.50	3.40	10.00	4.50	18.00	8.20
				2-1/2	65	9	229	7.50	3.40	10.00	4.50	18.00	8.20
				3 & 3-1/2	80 & 90	9	229	7.50	3.40	10.00	4.50	18.00	8.20
5	125	5-9/16	140	1 thru 1-1/2	25 thru 40	11	279	11.50	5.23	17.00	7.73	33.00	15.00
				2 & 2-1/2	50 & 65	11	279	11.50	5.23	17.00	7.73	33.00	15.00
				3 & 3-1/2	80 & 90	11	279	11.50	5.23	17.00	7.73	33.00	15.00
				4	100	11	279	11.50	5.23	17.00	7.73	33.00	15.00
6	150	6-5/8	168	1 thru 1-1/2	25 thru 40	12	305	17.00	7.73	25.00	11.40	46.00	21.00
				2 & 2-1/2	50 & 65	12	305	17.00	7.73	25.00	11.40	46.00	21.00
				3 & 3-1/2	80 & 90	12	305	17.00	7.73	25.00	11.40	46.00	21.00
				4	100	12	305	17.00	7.73	25.00	11.40	46.00	21.00
				5	125	12	305	17.00	7.73	25.00	11.40	46.00	21.00
8	200	8-5/8	219	2 thru 3	50 thru 80	13	330	29.00	13.20	44.00	20.00	78.00	36.00
				4 & 5	100 & 125	13	330	29.00	13.20	44.00	20.00	78.00	36.00
				6	150	13	330	29.00	13.20	44.00	20.00	78.00	36.00
10	250	10-3/4	273			15	381	48.00	22.00	66.00	30.00	130.00	59.00
12	300	12-3/4	324			18	457	75.00	34.00	98.00	45.00	180.00	85.00

BULL PLUGS

- Nominal Pipe size range 1/8 NPS / 6 DN – 12 NPS / 300 DN.
- Choice of raw material dependant upon size and reduction.
- Available standard, extra heavy, schedule 160, or double extra heavy or solid.
- End finishes available: current API threads or ANSI, beveled, square cut (for socket-weld), or grooved.
- All bull plugs can be tapped.
- Available round and hex.

SIZE											
PIPE		API or O.D.		LENGTH		STANDARD WEIGHT		EXTRA HEAVY WEIGHT		DBL EX. & 160 WEIGHT	
NPS	DN	IN	MM	IN	MM	LB	KG	LB	KG	LB	KG
1/8	6	.405	10	2	50			.10	.05	.40	.20
1/4	8	.540	15	2	50			.11	.05	.40	.20
3/8	10	.675	15	2-1/4	57			.14	.06	.28	.13
1/2	15	.840	20	2-1/2	63			.33	.15	.50	.23
3/4	20	1.050	25	2-3/4	70			.50	.23	.75	.34
1	25	1.315	33	3	76			.66	.30	1.00	.45
1-1/4	32	1.660	42	3-1/4	83	2.25	1.0	1.00	.45	1.50	.70
1-1/2	40	1.900	48	3-1/2	89	3.00	1.40	1.17	.53	2.00	.90
2	50	2-3/8	60	4	102	4.50	2.00	2.50	1.14	3.50	1.60
2-1/2	65	2-7/8	73	5	127	5.50	2.50	3.50	1.59	8.00	3.60
3	80	3-1/2	88	6	152	7.50	3.40	6.00	2.73	11.00	5.00
3-1/2	90	4	100	6-1/2	165	12.50	5.70	7.50	3.41	13.50	6.00
4	100	4-1/2	114	7	178	17.00	7.70	10.00	4.55	18.00	8.00
5	125	5-9/16	140	8-1/2	216	29.00	13.00	17.00	7.73	33.00	15.00
6	150	6-5/8	168	10	254	48.00	22.00	25.00	11.36	46.00	21.00
8	200	8-5/8	219	11	279	75.00	34.00	44.00	20.00	78.00	35.00
10	250	10-3/4	273	15	381			66.00	30.00	130.00	59.00
12	300	12-3/4	324	18	457			98.00	45.00	180.00	85.00

CURRENT API THREAD STANDARDS

SIZE		O.D.		PIPE	TUBING & CASING
NPS	DN	IN	MM		
3/4	20	1.050	25	14	
3/4 EUE	20	1.050	25		10 Rd.
1	25	1.315	33	11-1/2	10 Rd.
1 EUE	25	1.315	33		10 Rd.
1-1/4	32	1.660	42	11-1/2	10 Rd.
1-1/4 EUE	32	1.660	42		10 Rd.
1-1/2	40	1.900	48	11-1/2	10 Rd.
1-1/2 EUE	40	1.900	48		10 Rd.
2	50	2-3/8	60	11-1/2	10 Rd.
2 EUE	50	2-3/8	60		8 Rd.
2-1/2	65	2-7/8	73	8V	10 Rd.
2-1/2 EUE	65	2-7/8	73		8 Rd.
3	80	3-1/2	88	8V	10 Rd.
3 EUE	80	3-1/2	88		8 Rd.
3-1/2	90	4	100	8V	8 Rd.
3-1/2 EUE	90	4	100	8V	8 Rd.
4	100	4-1/2	114	8V	8 Rd.
4 EUE	100	4-1/2	114		8 Rd.
		5	125		8 Rd.
		5-1/2	140		8 Rd.
5	125	5-9/16	140	8V	
		6	150		8 Rd.
6	150	6-5/8	168	8V	8 Rd.
		7	180		8 Rd.
		7-5/8	195		8 Rd.
8	200	8-5/8	219	8V	8 Rd.
		9-5/8	245		8 Rd.
10	250	10-3/4	275	8V	8 Rd.
		11-3/4	300		8 Rd.
12	300	12-3/4	325	8V	
		13-3/8	340		8 Rd.
		14	355	8V	
		16	405	8V	8 Rd.
		18	455	8V	
		20	510	8V	8 Rd.

TUBING SWAGES

- Nominal sizes 1 – 3-1/2 / 25 – 90 DN upset and non-upset ends tubing swages available with any combination of current API threads (8 round, 10 round, 11-1/2 V, 8 V, etc.) and are stock items in J-55, K-55, N-80, and L-80
- Wall thicknesses available are standard through double extra heavy
- For different grades of material (stainless, brass, etc.) and different threads, consult factory
- Thread types are color-coded for easy identification.

LARGE END UPSET REDUCED TO REGULAR OR UPSET													
SIZE		API or O.D.		REDUCED TO		LENGTH		STANDARD WEIGHT		EXTRA HEAVY WEIGHT		DBL EX. & 160 WEIGHT	
NPS	DN	IN	MM	NPS	DN	IN	MM	LB	KG	LB	KG	LB	KG
1	25	1.315	33	3/4	20	3-1/2	89	.66	.3	.66	.3		
1-1/4	32	1.660	42	3/4 - 1	20 – 25	4	102	1.00	.45	1.00	.45		
1-1/2	40	1.900	48	3/4 - 1-1/4	20 – 32	4-1/2	114	1.25	.6	1.25	.6		
2	50	2-3/8	60	1/4 – 1/2 – 3/4	8 – 15 – 20	8	203	2.50	1.1	4.00	1.8	6.00	2.7
				1 – 1-1/4 – 1-1/2	25 – 32 – 40	8	203	2.50	1.1	4.00	1.8	6.00	2.7
				2-1/16 O.D.	52	8	203	2.5	1.1	4.00	1.8	6.00	2.7
2-1/2	65	2-7/8	73	1 – 1-1/4 – 1-1/2	25 – 32 – 40	8	203	5.00	2.2	6.00	2.7	10.00	4.5
				2	50	8	203	6.00	2.7	6.00	2.7	10.00	4.5
3	80	3-1/2	88	1 – 1-1/4 – 1-1/2	25 – 32 – 40	8	203	7.50	3.4	9.00	4.0	14.00	6.4
				2 – 2-1/2	50 – 65	8	203	7.50	3.4	9.00	4.0	14.00	6.4
4	100	4-1/2	114	1 – 1-1/4 – 1-1/2	25 – 32 – 40	9	229	11.00	5.0	14.00	6.4	23.00	10.5
				2 – 2-1/2	50 – 65	9	229	11.00	5.0	14.00	6.4	23.00	10.5
				3 – 3-1/2	80 – 90	9	229	11.00	5.0	14.00	6.4	23.00	10.5

LARGE END NON-UPSET REDUCED TO UPSET													
SIZE		API or O.D.		REDUCED TO		LENGTH		STANDARD WEIGHT		EXTRA HEAVY WEIGHT		DBL EX. & 160 WEIGHT	
NPS	DN	IN	MM	NPS	DN	IN	MM	LB	KG	LB	KG	LB	KG
1	25	1.315	33	3/4	20	3-1/2	89	.66	.3	.66	.66		
1-1/4	32	1.660	42	3/4 - 1	20 – 25	4	102	1.00	.45	1.00	1.00		
1-1/2	40	1.900	48	3/4 - 1-1/4	20 – 32	4-1/2	114	1.25	.6	1.25	1.25		
2	50	2-3/8	60	3/4	20	6.5	165	2.50	1.1	3.50	3.50	5.00	2.3
				1 – 1-1/4 – 1-1/2	25 – 32 – 40	6.5	165	2.50	1.1	3.50	3.50	5.00	2.3
2-1/2	65	2-7/8	73	1 – 1-1/4 – 1-1/2	25 – 32 – 40	7	178	4.00	1.8	6.00	6.00	9.00	4.0
				2	50	7	178	4.00	1.8	6.00	6.00	9.00	4.0
3	80	3-1/2	88	1 – 1-1/4 – 1-1/2	25 – 32 – 40	8	203	6.00	2.7	9.00	9.00	12.00	5.4
				2 – 2-1/2	50 – 65	8	203	6.00	2.7	9.00	9.00	12.00	5.4
4	100	4-1/2	114	1 – 1-1/4 – 1-1/2	25 – 32 – 40	9	229	8.00	2.7	12.00	12.00	20.00	9.0
				2 – 2-1/2	50 – 65	9	229	8.00	2.7	12.00	12.00	20.00	9.0
				3 – 3-1/2	80 – 90	9	229	8.00	2.7	12.00	12.00	20.00	9.0
		5-1/2	140	2 – 3	50 – 80	11	279	12.50	5.7	17.00	17.00	33.00	15.0
				2 – 3	50 – 80	12	305	17.00	7.7	25.00	25.00	50.00	23.0

OILFIELD BULL PLUGS

- 4-1/2" / 114 mm O.D. – 13-3/8" / 340 mm O.D. casing bull plugs available with all current API threads or beveled for welding
- Casing bull plugs available in standard, extra heavy or double extra heavy, and are manufactured from J-55, K-55, N-80, L-80, or WPB

TUBING BULL PLUGS											
SIZE				LENGTH		STANDARD WEIGHT		EXTRA HEAVY WEIGHT		DBL EX. & 160 WEIGHT	
PIPE		API or O.D.		IN	MM	LB	KG	LB	KG	LB	KG
3/4 EUE	20			3	76	1.50	.68	.50	.23		
1	25	1.315	35	3	76	1.50	.68	.66	.3		
1 EUE	25			3	76	1.50	.68				
1-1/4	32	1.660	40	3-1/4	83	1.50	.68	1.00	.45		
1-1/4 EUE	32			3-1/4	83	1.50	.68				
1-1/2	40	1.900	50	3-1/2	89	1.50	.68	1.06	.48		
1-1/2 EUE	40			3-1/2	89	2.00	.9	2.25	1.0		
2	50	2-3/8	60	4	102	2.00	.9	3.00	1.4	4.25	1.9
2 EUE	50			5	127	3.50	1.6	4.00	1.8	9.00	4.0
2-1/2	65	2-7/8	75	5	127	3.00	1.40	3.50	1.6	8.00	3.6
2-1/2 EUE	65			5-1/2	140	4.25	1.9	6.00	2.7	14.00	6.4
3	80	3-1/2	90	6	153	4.50	1.9	5.00	2.3	11.00	5.0
3 EUE	80			6-1/2	165	10.00	4.5	15.00	7.0	25.00	11.4
4	10	4-1/2	114	7	178	20.00	9	25.00	11.4	30.00	13.6
4 EUE	10			7	178	20.00	10	27.00	12.3	33.00	15

CASING BULL PLUGS										
	API or O.D.		LENGTH		STANDARD WEIGHT		EXTRA HEAVY WEIGHT		DBL EX. & 160 WEIGHT	
	IN	MM	IN	MM	LB	KG	LB	KG	LB	KG
	4-1/2	113	7	178	7.50	3.4	10.00	4.5	18.00	8.2
5	127	8	203	9.50	4.3	15.00	6.8	24.00	11.0	
5-1/2	140	8-1/2	216	12.50	5.7	17.00	7.7	33.00	15.0	
6-5/8	168	10	254	17.00	7.7	25.00	11.4	46.00	21.0	
7	175	10	254	17.00	7.7	25.00	11.4	50.00	23.0	
7-5/8	194	11	279	24.00	11.0	32.00	14.5	53.00	24.0	
8-5/8	219	11	279	29.00	13.0	44.00	20.0	78.00	35.0	

ADAPTER NIPPLES

BELL NIPPLES				
	O.D. SIZE		WEIGHT	
	NPS	MM	IN	MM
	4-1/2	113	4.5	2
5-1/2	140	9	4	
7	175	13.2	6	
8-5/8	219	15	7	
9-5/8	245			

- KEDDCO manufactures a full line of adapter nipples in sizes 1 NPS / 25 DN through 8 NPS / 200 DN from seamless A106 pipe
- Adapter nipples available in threaded, beveled, grooved and virtually all combinations of these end connections
- Nipples manufactured in schedule 40, schedule 80, schedule 160 and double extra heavy wall thickness
- Full traceability and mill certification available upon request at time of order

ADAPTER NIPPLES								
SEAMLESS SCHEDULE 40	API or O.D.		LENGTH		STANDARD WEIGHT		EXTRA HEAVY WEIGHT	
	IN	MM	IN	MM	LB	KG	LB	KG
	3/4	20				4	100	10.79
1	25				5	125	14.62	21.88
1-1/4	32				6	150	18.97	28.38
1-1/2	40				8	200	28.55	42.74
2	50	3.65	5.48		10	250	40.48	60.59
2-1/2	65	5.79	8.68		12	300	49.56	74.18
3	80	7.58	11.35					

- Std bull plugs listed above are made from J-55 (or better). Such items in XH and XXH are made from J-55, K-55, N-80 or the most appropriate material available.

TUBING NIPPLES

- Nominal sizes 1 – 4-1/2 / 25 – 100 DN upset and non-upset ends
- Lengths are 4” – 18”
- Tubing nipples available with any combination of current API threads (8 round, 10 round, 11-1/2 V, 8 V, etc.) and are stock items in J-55, K-55, N-80, and L-80
- Wall thicknesses available are standard through double extra heavy
- For different grades of material (stainless, brass, etc.) and different threads, consult factory

Tubing nipples standard weight	SIZE			END CONNECTION
	NPS	API	DN	
18” / 457 mm and shorter upset and non-upset	1	1.315	25	Upset API Threads: One or Both Ends (EUE)
	1		25	Non-upset (Regular) (NUE)
	1-1/4	1.66	32	Upset API Threads: One or Both Ends (EUE)
	1-1/4		32	Non-upset (Regular) (NUE)
	1-1/2	1.99	40	Upset API Threads: One or Both Ends (EUE)
	1-1/2		40	Non-upset (Regular) (NUE)
	2	2.375	50	Upset API Threads: One or Both Ends (EUE)
	2		50	Non-upset (Regular) (NUE)
	2-1/2	2.875	65	Upset API Threads: One or Both Ends (EUE)
	2-1/2		65	Non-upset (Regular) (NUE)
	3	3.5	80	Upset API Threads: One or Both Ends (EUE)
	3		80	Non-upset (Regular) (NUE)
	4	4.50	100	Upset API Threads: One or Both Ends (EUE)
	4		100	Non-upset (Regular) (NUE)
	Tubing nipples extra heavy weight	SIZE		
NPS		API	DN	
18” / 457 mm and shorter upset and non-upset	1	1.315	25	Upset API Threads: One or Both Ends (EUE)
	1		25	Non-upset (Regular) (NUE)
	1-1/4	1.66	32	Upset API Threads: One or Both Ends (EUE)
	1-1/4		32	Non-upset (Regular) (NUE)
	1-1/2	1.99	40	Upset API Threads: One or Both Ends (EUE)
	1-1/2		40	Non-upset (Regular) (NUE)
	2	2.375	50	Upset API Threads: One or Both Ends (EUE)
	2		50	Non-upset (Regular) (NUE)
	2-1/2	2.875	65	Upset API Threads: One or Both Ends (EUE)
	2-1/2		65	Non-upset (Regular) (NUE)
	3	3.5	80	Upset API Threads: One or Both Ends (EUE)
	3		80	Non-upset (Regular) (NUE)
	4	4.50	100	Upset API Threads: One or Both Ends (EUE)
	4		100	Non-upset (Regular) (NUE)

CASING NIPPLES

OIL COUNTRY CASING NIPPLES	SIZE		WEIGHT		STEEL GRADE
	NPS	DN	NPS	DN	
	4-1/2	114	10.50	15.70	K
			11.60	17.36	K-N-P
	5	125	11.50	17.36	K
			13.00	19.47	K
			15.00	22.44	K-N-P
			18.00	26.93	N-P
	5-1/2	140	14.00	20.98	K
			15.50	23.20	K
			17.00	25.44	K-N-P
			20.00	29.93	N-P
	6-5/8	168	20.00	29.93	K
			24.00	35.94	K-N-P
			28.00	41.91	N-P
	7	175	20.00	29.93	K
			23.00	34.42	K-N
			26.00	38.91	K-N-P
			29.00	43.40	N-P
	7-5/8	194	26.40	39.50	K-N
			29.70	44.45	N-P
	8-5/8	219	24.00	35.94	K
			32.00	47.88	K
			36.00	53.89	K-N-P
			44.00	65.87	N-P
			49.00	73.36	N-P
	9-5/8	245	36.00	53.89	K
			40.00	59.86	K-N
			43.50	65.11	N-P
			47.00	70.36	N-P
	10-3/4	273	40.50	60.62	K
			45.50	68.11	K
			55.50	83.06	N-P
	11-3/4	298	60.00	89.83	K
	13-3/8	340	54.50	81.58	K
			61.00	91.31	K
			68.00	101.77	K
			72.00	107.78	K
	16	400	75.00	112.27	K
			84.00	125.73	K

OILFIELD COUPLINGS

GRADE	5CT SPECIFICATION	COLOR SPECIFICATION
H-40	GROUP ONE	UNPAINTED OR BLACK
J-55, K-55	GROUP ONE	GREEN
N-80	GROUP ONE	RED
L-80	GROUP TWO	RED WITH BROWN BAND
C-90	GROUP TWO	PURPLE
C-95	GROUP TWO	BROWN
P110	GROUP THREE	WHITE
Q-125	GROUP FOUR	ORANGE

API EXTERNAL UPSET END (EUE) TUBING COUPLINGS

CPLG SIZE	PIPE SIZE	COUPLING O.D.		MINIMUM LENGTH	THREADS PER INCH	WEIGHT			CTN QTY
		REGULAR	SPECIAL CLEARANCE			REGULAR	SPECIAL CLEARANCE	SPECIAL BEVEL	
1.050	3/4	1.660	----	3 1/4	10	0.84	----	----	1500
1.315	1	1.990	----	3 1/2	10	1.26	----	----	1200
1.660	1 1/4	2.200	----	3 3/4	10	1.49	----	----	800
1.900	1 1/2	2.500	----	3 7/8	10	1.85	----	----	600
2 3/8	2	3.063	2.910	4 7/8	8	3.42	2.38	3.29	1144
2 7/8	2 1/2	3.668	3.460	5 1/4	8	5.29	3.45	5.07	792
3 1/2	3	4.500	4.180	5 3/4	8	9.02	5.22	8.55	448
4	3 1/2	5.000	----	6	8	10.62	----	----	245
4 1/2	4	5.563	----	6 1/4	8	13.31	----	----	210

API NONUPSET END (EUE) TUBING COUPLINGS

CPLG SIZE	PIPE SIZE	COUPLING O.D.		MINIMUM LENGTH	THREADS PER INCH	WEIGHT			CTN QTY
		REGULAR	SPECIAL CLEARANCE			REGULAR	SPECIAL CLEARANCE	SPECIAL BEVEL	
1.315	1	1.660	----	3 1/4	10	0.84	----	----	1500
1.660	1 1/4	2.054	----	3 1/2	10	1.26	----	----	1000
1.900	1 1/2	2.200	----	3 3/4	10	1.25	----	----	800
2 3/8	2	2.875	----	4 1/4	10	2.82	----	2.69	1144
2 7/8	2 1/2	3.500	----	5 1/8	10	5.15	----	4.90	792
3 1/2	3	4.250	----	5 5/8	10	8.17	----	7.73	256
4	3 1/2	4.750	----	5 3/4	8	9.57	----	----	360
4 1/2	4	5.200	----	6 1/8	8	10.76	----	----	235

API BUTTRESS THREAD CASING COUPLINGS

PIPE SIZE	COUPLING O.D.		MINIMUM LENGTH	WEIGHT		CARTON QUANTITY
	REGULAR	SPECIAL CLEARANCE		REGULAR	SPECIAL CLEARANCE	
4 1/2	5.000	4.875	8 7/8	10.11	7.67	196
5	5.563	5.375	9 1/8	12.99	8.81	196
5 1/2	6.050	5.875	9 1/4	14.14	9.84	136
6 5/8	7.390	7.000	9 5/8	24.46	12.44	100
7	7.656	7.375	10	23.22	13.82	84
7 5/8	8.500	8.125	10 3/8	34.84	20.45	64
8 5/8	9.625	9.125	10 5/8	45.94	23.77	52
9 5/8	10.625	10.125	10 5/8	50.99	26.47	40
10 3/4	11.750	11.250	10 5/8	56.68	29.49	45
11 3/4	12.750	----	10 5/8	61.74	----	40
13 3/8	14.375	----	10 5/8	69.95	----	25
16	17.000	----	10 5/8	87.56	----	20
18 5/8	20.000	----	10 5/8	138.03	----	12
20	21.000	----	10 5/8	110.33	----	8

Note: All buttress couplings are 5 threads per inch with 4 1/2 thru 13 3/8 taper tapped 3/4" per foot on diameter and 16" thru 20" taper tapped 1" per foot.

OILFIELD COUPLINGS CONTINUED

API ROUND THREAD CASING COUPLINGS

PIPE SIZE	COUPLING O.D.	MINIMUM LENGTH		WEIGHT		CARTON QUANTITY	
		SHORT	LONG	SHORT	LONG	SHORT	LONG
4 1/2	5.000	6 1/4	7	8.05	9.07	294	294
5	5.563	6 1/2	7 3/4	10.18	12.56	252	210
5 1/2	6.050	6 3/4	8	11.44	14.03	216	180
6 5/8	7.390	7 1/4	8 3/4	19.97	24.82	120	92
7	7.656	7 1/4	9	18.34	23.67	120	100
7 5/8	8.500	7 1/2	9 1/4	26.93	34.23	80	64
8 5/8	9.625	7 3/4	10	35.58	47.48	60	60
9 5/8	10.625	7 3/4	10 1/2	39.51	55.77	50	36
10 3/4	11.750	8	10 1/2	45.53	62.02	45	36
11 3/4	12.750	8	10 1/2	49.61	67.39	40	40
13 3/8	14.375	8	10 1/2	56.23	76.63	25	20
16	17.000	9	11	79.00	96.55	20	20
18 5/8	20.000	9	-----	118.94	-----	8	-----
20	21.000	9	11 1/2	98.25	126.74	8	8

Note: Both LTC and STC couplings are 8 threads per inch and taper tapped 3/4" per foot on diameter

IMPROVED BUTTRESS THREAD TUBING COUPLINGS

CPLG SIZE	PIPE SIZE	COUPLING O.D.		MINIMUM LENGTH	THREADS PER INCH	WEIGHT			CTN QTY
		REGULAR	SPECIAL CLEARANCE			REGULAR	SPECIAL CLEARANCE	SPECIAL BEVEL	
2 3/8	2	2.875	2.700	8 1/2	8	5.46	3.62	-----	644
2 7/8	2 1/2	3.500	3.220	8 1/2	8	8.14	4.59	-----	400
3 1/2	3	4.250	3.865	8 1/2	8	11.74	5.83	-----	248
4	3 1/2	4.750	4.400	9	8	14.17	7.75	-----	-----
4 1/2	4	5.200	4.920	9 1/2	8	15.72	9.73	-----	196

Note: All USS Improved Buttress couplings are 8 threads per inch. Regular O.D. and special clearance furnished with 20° bevel both ends.

PUP JOINTS

UPSET

NPS	API	End Connections	2 ft.	3 ft.	4 ft.	6 ft.	8 ft.	10 ft.	12 ft.
			Weight Each	Weight Each	Weight Each	Weight Each	Weight Each	Weight Each	Weight Each
2"	2 3/8"	Upset A.P.I. Thds. One or Both Ends	8 3/4	13 1/4	17 3/4	26 1/2	35 1/2	44 1/4	52 1/2
2"	2 3/8"	Non-upset (Regular)	9	13	18	26 1/2	35 1/2	44 1/4	53
2"	2 3/8"	Integral Joint Box & Pin	9	13 1/4	18	26 1/2	35 1/2	44 1/4	53
2 1/2"	2 7/8"	Upset A.P.I. Thds. One or Both Ends	12 1/2	18 1/2	25 1/2	38	50 1/4	62 1/2	76
2 1/2"	2 7/8"	Non-upset (Regular)	12 1/2	18 1/2	24 1/2	37	49	61 1/2	74
2 1/2"	2 7/8"	Integral Joint Box & Pin	12 1/2	18 1/2	25 1/2	38	50 1/4	62 1/2	76
3"	3 1/2"	Upset A.P.I. Thds. One or Both Ends	17 1/2	26 1/2	35 1/4	52 3/4	70 1/4	88	105 1/2
3"	3 1/2"	Non-upset (Regular)	17 1/2	26 1/2	35	53	70	88	105

Perforation Only - Upset
Standard Performations 3/8" hole.

STEEL LINE BLANKS

Note To Purchaser

1. If the purchaser needs a steel line blank that deviates from this standard, the deviating requirements shall be stated in the purchase order.
2. If no exceptions are to be taken to this standard, the purchase order need only make reference to ASME B16.48 and specify the items marked with an asterisk (*) in the following list. Other items listed are options that may also be specified if required.
 - *a. Size (see pages C4 - C17).
 - *b. Class (see pages C4 - C17).
 - *c. Facing (Standard 125 - 250 RMS).
 - *d. Style (see Fig. 1, 2 or 3).
 - *e. Plate material (see Table page C3).
 - f. Inside diameter (if other than standard).
 - g. Lifting or handling device.
3. All Keddco spec blinds are manufactured to ASME B16.48 unless otherwise specified.

GENERAL

This standard provides dimensions for operating line blanks (or "blinds") in sizes NPS 1/2 through NPS 24 for installation between ANSI B16.5 flanges in the 150, 300, 600, 900, 1500, and 2500 pound pressure classes. Line blanks used only for pressure testing are not part of this standard.

A Figure 8 blank (also called a spectacle blind) is a pressure retaining plate with one solid end and one open end connected with a web or tie bar (see Figure 1).

Keddco reserves the right to supply the web design (integral, double tie-bar, single wedge) that best suits the use of the raw material in the construction of the spectacle blind.

A paddle blank is similar to the solid end of a figure 8 blank (with a handle) and is generally used in conjunction with a paddle spacer in large sizes (see Figure 2).

A paddle spacer is similar to the open end figure 8 blank (with a handle) and is generally used in conjunction with a paddle blank (see Figure 3).

Paddle spacer handles shall have one 1/2 inch (13 millimeter) minimum diameter hole located near the outer end. This hole serves as a remote visual indicator.

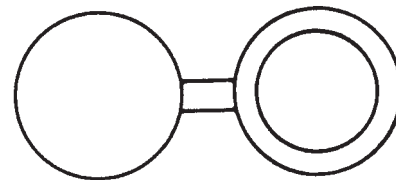

FIG. 1

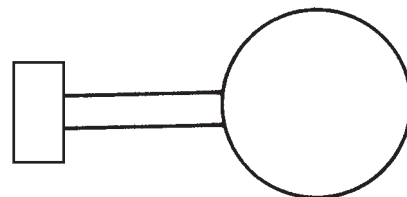

FIG. 2

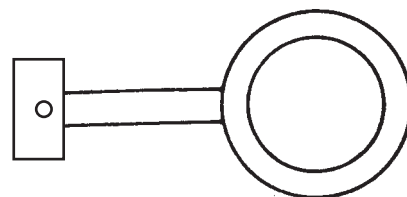

FIG. 3

CAUTION: Paddle blanks shall not be supplied with indicator or bolt holes.

SECTION - RATING

Pressure - Temperature Ratings

Pressure-temperature ratings are those listed in ANSI B16.5 and B16.34 standard class for the material group corresponding to the plate materials.

ANSI Class

Line blanks covered by this standard are for the following ANSI classes: 150, 300, 600, 900, 1500, and 2500.

MATERIALS	FORGING SPEC. -GR	PLATES SPEC. -GR
CARBON	A105	A516-70
CARBON	A350-LF2	A516-70 NORM
1-1/4 Cr-1/2 Mo	A182-F11	A387-11 CL.2
2-1/4 Cr-1 Mo	A182-F22	A387-22 CL.3
5 Cr-1/2 Mo	A182-F5	A387-5 CL.4
9 Cr-9 Mo	A182-F9	A387-9 CL.5
304SS	A182-GR.F304	A240 GR.304
316SS	A182-GR.F316	A240 GR.316
321SS	A182-GR.F321	A240 GR.321
347SS	A182-GR.F347	A240 GR.347

Note: Other materials available upon request
 Approved weld procedures for all of the above materials

FIGURE 8 BLINDS

Dimensions of Class 150 Raised Face Figure 8 Blanks

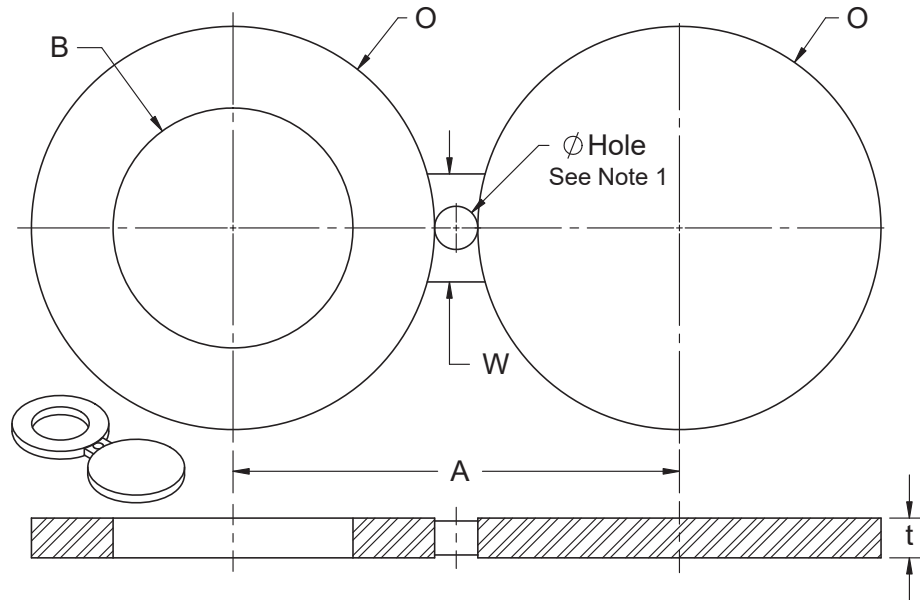

NPS	Inside Diameter B		Outside Diameter O		Centerline Dimension A		Thickness t		Web Width W		HOLE	WGT
	In.	mm.	In.	mm.	In.	mm.	In.	mm.	In.	mm.		
1/2	0.62	16	1.75	44	2.38	60	0.12	3	1.50	38	0.62	0.3
3/4	0.82	21	2.12	54	2.75	70	0.12	3	1.50	38	0.62	0.3
1	1.05	27	2.50	64	3.12	79	0.12	3	1.50	38	0.62	0.3
1 1/4	1.66	42	2.88	73	3.50	89	0.25	6	1.50	38	0.62	0.5
1 1/2	1.90	48	3.25	83	3.88	99	0.25	6	1.50	38	0.62	0.7
2	2.38	60	4.00	102	4.75	121	0.25	6	2.00	51	0.75	0.9
2 1/2	2.88	73	4.75	121	5.50	140	0.25	6	2.00	51	0.75	1.8
3	3.50	89	5.25	133	6.00	152	0.25	10	2.50	64	0.75	2.7
3 1/2	4.00	102	6.25	159	7.00	178	0.38	10	2.50	64	0.75	3.4
4	4.50	114	6.75	171	7.50	190	0.38	10	2.50	64	0.75	4.0
5	5.56	141	7.62	194	8.50	216	0.38	13	3.00	76	0.88	6.7
6	6.62	168	8.62	219	9.50	241	0.50	13	3.00	76	0.88	9.4
8	8.62	219	10.88	276	11.75	298	0.50	13	3.00	76	0.88	19.1
10	10.75	273	13.25	337	14.25	362	0.62	16	4.00	102	1.00	32.0
12	12.75	324	16.00	406	17.00	432	0.75	19	4.00	102	1.00	56.0
14	14.00	356	17.62	448	18.75	476	0.75	19	4.25	108	1.12	79.0
16	16.00	406	20.12	511	21.25	540	0.88	22	4.25	108	1.12	115.0
18	18.00	457	21.50	546	22.75	578	1.00	25	4.50	114	1.25	138.0
20	20.00	508	23.75	603	25.00	635	1.12	28	4.75	121	1.25	179.0
24	24.00	610	28.12	714	29.50	749	1.25	32	5.50	140	1.38	306.0

Note: Hole size (where required due to bolt spacing) shall be the same as the flange bolt hole.

FIGURE 8 BLINDS

Dimensions of Class 300 Raised Face Figure 8 Blanks

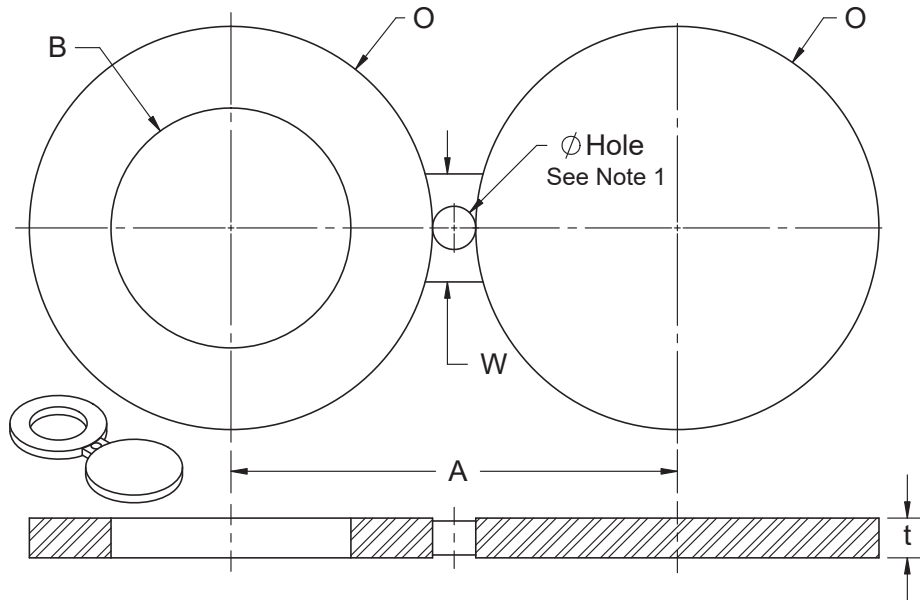

NPS	Inside Diameter <i>B</i>		Outside Diameter <i>O</i>		Centerline Dimension <i>A</i>		Thickness <i>t</i>		Web Width <i>W</i>		HOLE	WGT
	In.	mm.	In.	mm.	In.	mm.	In.	mm.	In.	mm.		
1/2	0.62	16	2.00	51	2.62	67	0.25	6	1.50	38	0.62	0.5
3/4	0.82	21	2.50	64	3.25	83	0.25	6	1.50	38	0.75	0.5
1	1.05	27	2.75	70	3.50	89	0.25	6	1.50	38	0.75	0.5
1 1/4	1.66	42	3.12	79	3.88	99	0.25	6	1.50	38	0.75	0.9
1 1/2	1.90	48	3.62	92	4.50	114	0.25	6	1.50	51	0.88	1.3
2	2.38	60	4.25	108	5.00	127	0.38	10	2.00	51	0.75	1.8
2 1/2	2.88	73	5.00	127	5.88	149	0.38	10	2.00	64	0.88	2.4
3	3.50	89	5.75	146	6.62	168	0.38	10	2.50	64	0.88	2.9
3 1/2	4.00	102	6.38	162	7.25	184	0.50	13	2.50	64	0.88	5.4
4	4.50	114	7.00	178	7.88	200	0.50	13	2.50	64	0.88	7.8
5	5.56	141	8.38	213	9.25	235	0.62	16	3.00	76	0.88	14.0
6	6.62	168	9.75	248	10.62	270	0.62	16	3.00	76	0.88	20.1
8	8.62	219	12.00	305	13.00	330	0.88	22	3.00	89	1.00	40.0
10	10.75	273	14.12	359	15.25	387	1.00	25	4.00	102	1.12	65.0
12	12.75	324	16.50	419	17.75	451	1.12	28	4.00	102	1.25	103.0
14	14.00	356	19.00	483	20.25	514	1.25	32	4.25	108	1.25	153.0
16	16.00	406	21.12	537	22.50	572	1.50	38	4.25	108	1.38	215.0
18	18.00	457	23.38	594	24.75	629	1.62	41	4.50	114	1.38	295.0
20	20.00	508	25.62	651	27.00	686	1.75	44	4.75	121	1.38	374.0
24	24.00	610	30.38	772	32.00	813	2.00	51	5.50	140	1.62	625.0

Note: Hole size (where required due to bolt spacing) shall be the same as the flange bolt hole.

FIGURE 8 BLINDS

Dimensions of Class 600 Raised Face Figure 8 Blanks

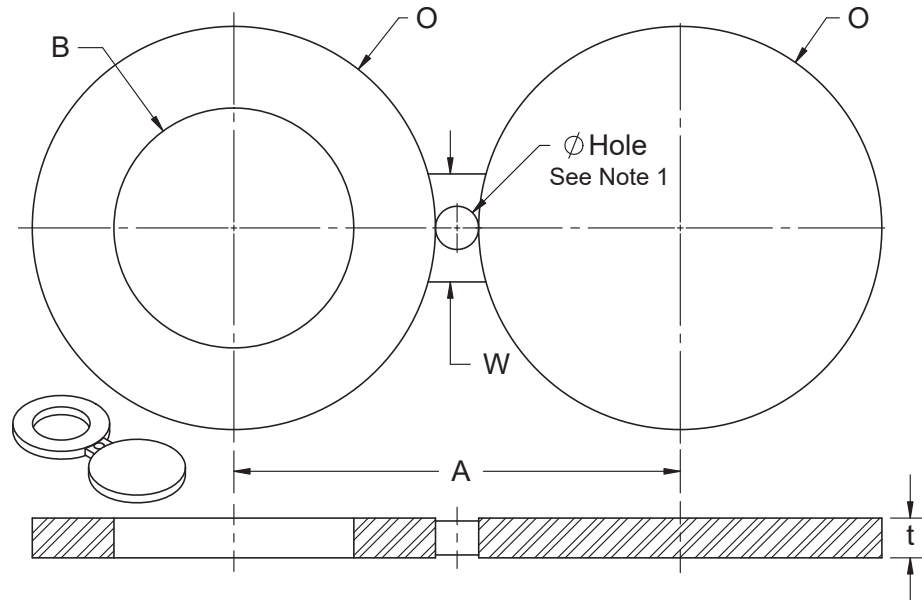

NPS	Inside Diameter <i>B</i>		Outside Diameter <i>O</i>		Centerline Dimension <i>A</i>		Thickness <i>t</i>		Web Width <i>W</i>		HOLE	WGT
	In.	mm.	In.	mm.	In.	mm.	In.	mm.	In.	mm.		
1/2	0.62	16	2.00	51	2.62	67	0.25	6	1.50	38	0.62	0.5
3/4	0.82	21	2.50	64	3.25	83	0.25	6	1.50	38	0.75	0.5
1	1.05	27	2.75	70	3.50	89	0.25	6	2.25	57	0.75	0.8
1 1/4	1.44	37	3.12	79	3.88	99	0.38	10	2.25	57	0.75	1.1
1 1/2	1.68	43	3.62	92	4.50	114	0.38	10	2.62	67	0.88	1.3
2	2.16	55	4.25	108	5.00	127	0.38	10	2.25	57	0.75	2.2
2 1/2	2.64	67	5.00	127	5.88	149	0.50	13	2.62	67	0.88	3.9
3	3.26	83	5.75	146	6.62	168	0.50	13	2.62	67	0.88	5.5
3 1/2	3.76	96	6.25	159	7.25	184	0.62	16	3.00	76	1.00	8.8
4	4.26	108	7.50	191	8.50	216	0.62	16	3.00	76	1.00	12.0
5	5.30	135	9.38	238	10.50	267	0.75	19	3.38	86	1.12	23.5
6	6.36	162	10.38	264	11.50	292	0.88	22	3.38	86	1.12	35.0
8	8.33	212	12.50	318	13.75	349	1.12	28	3.75	95	1.25	60.0
10	10.42	265	15.62	397	17.00	432	1.38	35	4.12	105	1.38	117.5
12	12.39	315	17.88	454	19.25	489	1.62	41	4.12	105	1.38	185.0
14	13.62	346	19.25	489	20.75	527	1.75	44	4.50	114	1.50	230.0
16	15.62	397	22.12	562	23.75	603	2.00	51	4.88	124	1.62	340.0
18	17.62	448	24.00	610	25.75	654	2.12	54	5.25	133	1.75	450.0
20	19.56	497	26.75	679	28.50	724	2.50	64	5.25	133	1.75	620.0
24	23.50	597	31.00	787	33.00	838	2.88	73	6.00	152	2.00	975.0

Note: Hole size (where required due to bolt spacing) shall be the same as the flange bolt hole.

FIGURE 8 BLINDS

Dimensions of Class 900 Raised Face Figure 8 Blanks

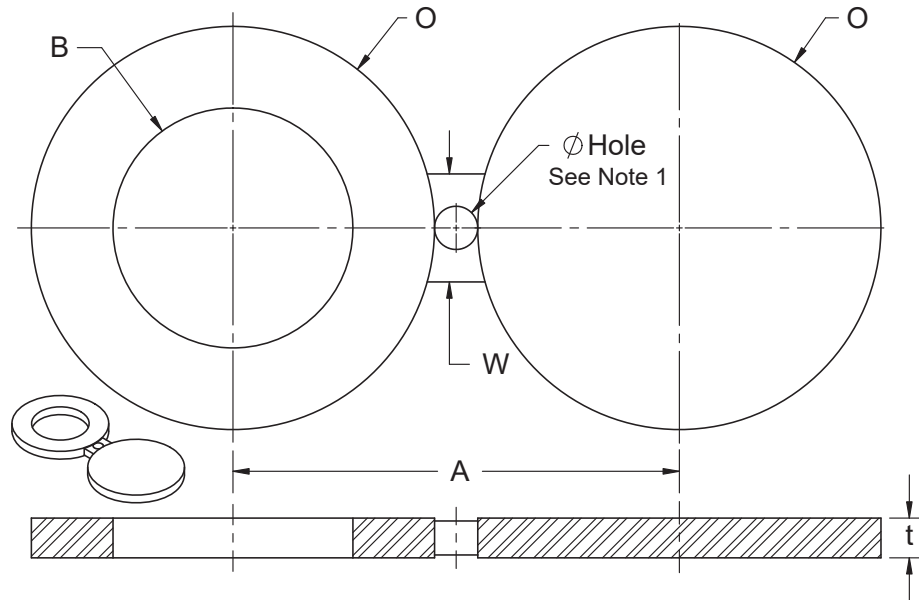

NPS	Inside Diameter <i>B</i>		Outside Diameter <i>O</i>		Centerline Dimension <i>A</i>		Thickness <i>t</i>		Web Width <i>W</i>		HOLE	WGT
	In.	mm.	In.	mm.	In.	mm.	In.	mm.	In.	mm.		
1/2	0.62	16	2.38	60	3.25	83	0.25	6	1.50	38	0.88	0.5
3/4	0.82	21	2.62	67	3.50	89	0.25	6	1.62	41	0.88	0.5
1	1.05	27	3.00	76	4.00	102	0.25	6	2.25	57	1.00	0.9
1 1/4	1.44	37	3.38	86	4.38	111	0.38	10	2.25	57	1.00	1.4
1 1/2	1.68	43	3.75	95	4.88	124	0.38	10	2.62	67	1.12	1.8
2	2.16	55	5.50	140	6.50	165	0.50	13	2.25	57	1.00	4.7
2 1/2	2.64	67	6.38	162	7.50	190	0.50	13	2.62	67	1.12	7.1
3	3.26	83	6.50	165	7.50	190	0.62	16	2.62	67	1.00	9.5
4	4.26	108	8.00	203	9.25	235	0.75	19	3.00	76	1.25	17.0
5	5.30	135	9.62	244	11.00	279	0.88	22	3.38	86	1.38	34.8
6	6.36	162	11.25	286	12.50	318	1.00	25	3.38	86	1.25	52.5
8	8.33	212	14.00	356	15.50	394	1.38	35	3.75	95	1.50	97.0
10	10.42	265	17.00	432	18.50	470	1.62	41	4.12	105	1.50	178.0
12	12.39	315	19.50	495	21.00	533	1.88	48	4.12	105	1.50	280.0
14	13.62	346	20.38	518	22.00	559	2.12	54	4.50	114	1.62	305.0
16	15.62	397	22.50	572	24.25	616	2.38	60	4.88	124	1.75	410.0
18	17.62	448	25.00	635	27.00	686	2.62	67	5.25	133	2.00	570.0
20	19.56	497	27.38	695	29.50	749	2.88	73	5.25	133	2.12	750.0
24	23.50	597	32.88	835	35.50	902	3.50	89	6.00	152	2.62	1250.0

Note: Hole size (where required due to bolt spacing) shall be the same as the flange bolt hole.

FIGURE 8 BLINDS

Dimensions of Class 1500 Raised Face Figure 8 Blanks

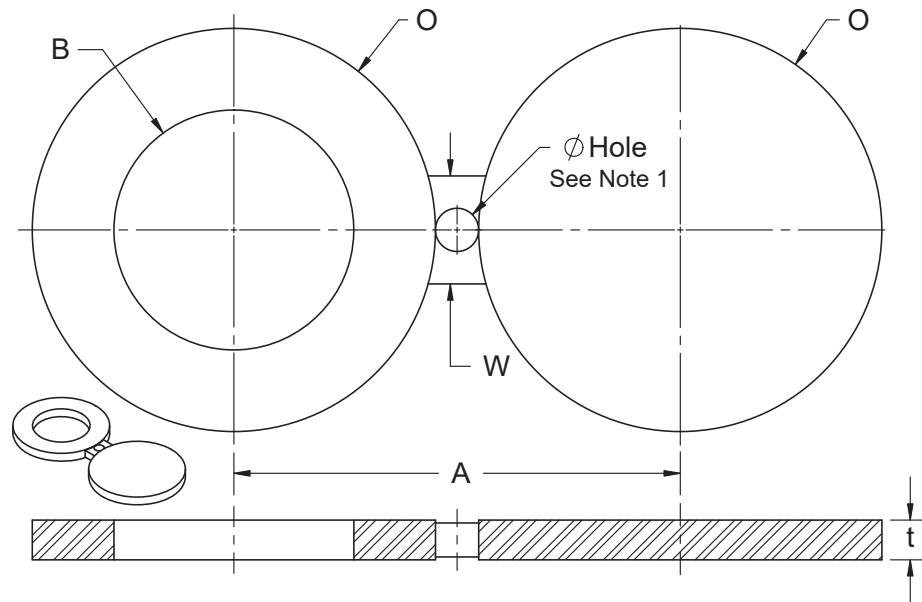

NPS	Inside Diameter <i>B</i>		Outside Diameter <i>O</i>		Centerline Dimension <i>A</i>		Thickness <i>t</i>		Web Width <i>W</i>		HOLE	WGT
	In.	mm.	In.	mm.	In.	mm.	In.	mm.	In.	mm.		
1/2	0.62	16	2.38	60	3.25	83	0.25	6	1.50	38	0.88	0.6
3/4	0.82	21	2.62	67	3.50	89	0.38	10	1.62	41	0.88	1.1
1	1.05	27	3.00	76	4.00	102	0.38	10	2.50	64	1.00	1.4
1 1/4	1.38	35	3.38	86	4.38	111	0.38	10	2.50	64	1.00	1.8
1 1/2	1.61	41	3.75	95	4.88	124	0.50	13	2.75	70	1.12	2.8
2	2.07	53	5.50	140	6.50	165	0.50	13	2.75	70	1.00	6.3
2 1/2	2.47	63	6.38	162	7.50	190	0.62	16	3.00	76	1.12	10.4
3	3.07	78	6.75	171	8.00	203	0.75	19	3.00	76	1.25	14.0
4	4.03	102	8.12	206	9.50	241	0.88	22	3.50	89	1.38	22.0
5	5.05	128	9.88	251	11.50	292	1.12	28	3.50	89	1.62	42.0
6	6.06	154	11.00	279	12.50	318	1.38	35	3.50	89	1.50	63.0
8	7.98	203	13.75	349	15.50	394	1.62	41	4.00	102	1.75	113.0
10	10.02	255	17.00	432	19.00	483	2.00	51	4.50	114	2.00	213.0
12	11.94	303	20.38	518	22.50	572	2.38	60	4.50	114	2.12	365.0
14	13.12	333	22.62	575	25.00	635	2.62	67	5.00	127	2.38	497.0
16	15.00	381	25.12	638	27.75	705	3.00	76	5.25	133	2.62	693.0
18	16.88	429	27.62	702	30.50	775	3.38	86	5.75	146	2.88	934.0
20	18.81	478	29.62	752	32.75	832	3.75	95	6.00	152	3.12	1170.0
24	22.62	575	35.38	899	39.00	991	4.38	111	7.00	178	3.62	1547.0

Note: Hole size (where required due to bolt spacing) shall be the same as the flange bolt hole.

FIGURE 8 BLINDS

Dimensions of Class 2500 Raised Face Figure 8 Blanks

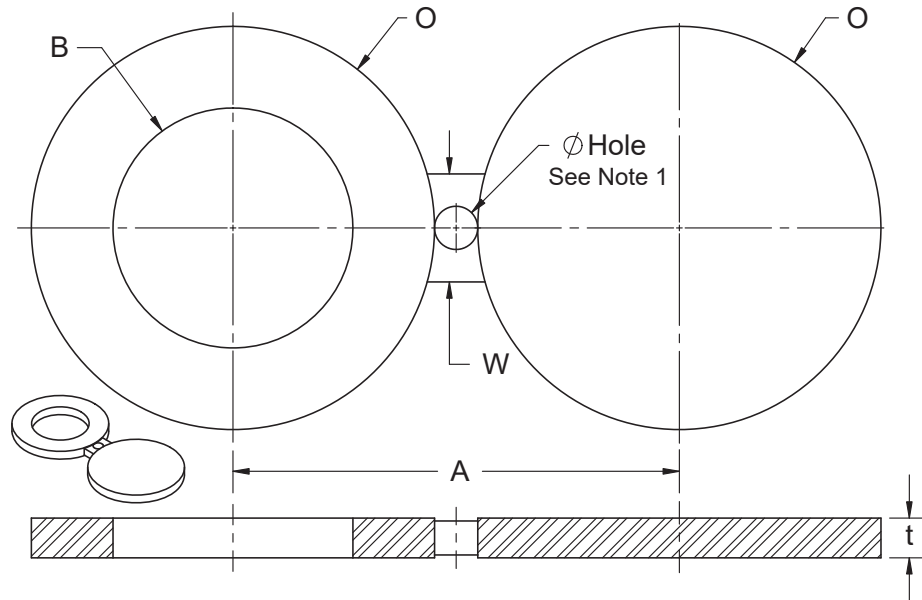

NPS	Inside Diameter <i>B</i>		Outside Diameter <i>O</i>		Centerline Dimension <i>A</i>		Thickness <i>t</i>		Web Width <i>W</i>		HOLE	WGT
	In.	mm.	In.	mm.	In.	mm.	In.	mm.	In.	mm.		
1/2	0.62	16	2.62	67	3.50	89	0.38	10	1.50	38	0.88	1.1
3/4	0.82	21	2.88	73	3.75	95	0.38	10	1.62	41	0.88	1.3
1	1.05	27	3.25	83	4.25	108	0.38	10	2.50	64	1.00	1.7
1 1/4	1.38	35	4.00	102	5.12	130	0.50	13	2.50	64	1.12	3.4
1 1/2	1.61	41	4.50	114	5.75	146	0.62	16	2.75	70	1.25	5.2
2	2.07	53	5.62	143	6.75	171	0.62	16	2.75	70	1.12	8.1
2 1/2	2.47	63	6.50	165	7.75	197	0.75	19	3.00	76	1.25	13.1
3	3.07	78	7.62	194	9.00	229	0.88	22	3.00	76	1.38	21.0
4	4.03	102	9.12	232	10.75	273	1.12	28	3.50	89	1.62	37.0
5	5.05	128	10.88	276	12.75	324	1.38	35	3.50	89	1.88	65.0
6	6.06	154	12.38	314	14.50	368	1.62	41	3.50	89	2.12	97.0
8	7.81	198	15.12	384	17.25	438	2.12	54	4.00	102	2.12	187.0
10	9.75	248	18.62	473	21.25	540	2.62	67	4.50	114	2.62	349.0
12	11.37	289	21.50	546	24.38	619	3.12	79	4.50	114	2.88	553.0

Note: Hole size (where required due to bolt spacing) shall be the same as the flange bolt hole.

RING TYPE JOINTS

Dimensions of Class 150 Female Ring-Joint Facing Figure 8 Blanks

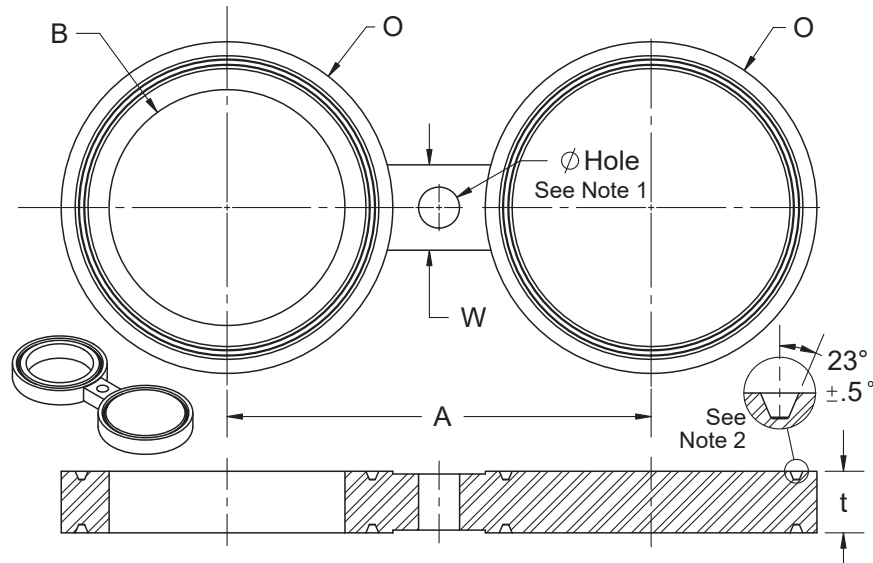

NPS	Inside Diameter <i>B</i>		Outside Diameter <i>O</i>		Centerline Dimension <i>A</i>		Thickness <i>t</i>		Web Width <i>W</i>		HOLE	WGT
	In.	mm.	In.	mm.	In.	mm.	In.	mm.	In.	mm.		
1	1.32	34	2.50	64	3.12	79	0.75	19	2.00	51	0.62	3.0
1 1/4	1.66	42	2.88	73	3.50	89	0.75	19	2.00	51	0.62	4.0
1 1/2	1.90	48	3.25	83	3.88	99	0.75	19	2.25	57	0.62	5.0
2	2.38	60	4.00	102	4.75	121	0.75	19	2.25	57	0.75	5.0
2 1/2	2.88	73	4.75	121	5.50	140	0.88	22	2.25	57	0.75	10.0
3	3.50	89	5.25	133	6.00	152	0.88	22	2.25	57	0.75	15.0
3 1/2	4.00	102	6.06	154	7.00	178	0.88	22	2.50	64	0.75	17.5
4	4.50	114	6.75	171	7.50	190	0.88	22	2.50	64	0.75	20.0
5	5.56	141	7.62	194	8.50	216	1.00	25	2.75	70	0.88	30.0
6	6.62	168	8.62	219	9.50	241	1.00	25	3.25	83	0.88	40.0
8	8.62	219	10.75	273	11.75	298	1.12	28	3.75	95	0.88	60.0
10	10.75	273	13.00	330	14.25	362	1.25	32	4.00	102	1.00	80.0
12	12.75	324	16.00	406	17.00	432	1.38	35	4.75	121	1.00	100.0
14	14.00	356	16.75	425	18.75	476	1.38	34	5.00	127	1.12	120.0
16	16.00	406	19.00	483	21.25	540	1.50	38	5.00	127	1.12	150.0
18	18.00	457	21.50	546	22.75	578	1.62	41	5.00	127	1.25	200.0
20	20.00	508	23.50	597	25.00	635	1.62	41	5.00	127	1.25	250.0
24	24.00	610	28.00	711	29.50	749	1.88	48	6.00	152	1.38	400.0

Note: 1. Hole size (where required due to bolt spacing) shall be the same as the flange bolt hole.

Note: 1. Female ring joint groove dimensions shall be designed for octagonal rings in accordance with ANSI B16.5.

RING TYPE JOINTS

Dimensions of Class 300 Female Ring-Joint Facing Figure 8 Blanks

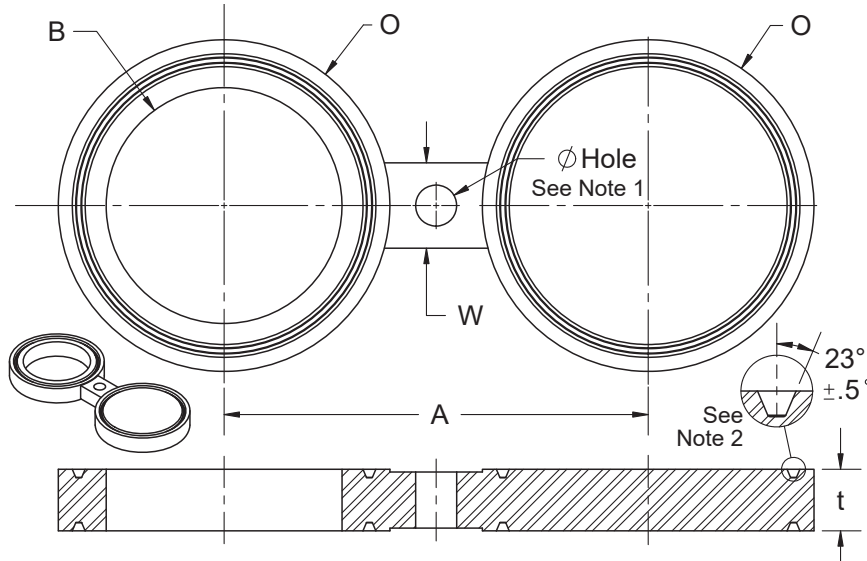

NPS	Inside Diameter <i>B</i>		Outside Diameter <i>O</i>		Centerline Dimension <i>A</i>		Thickness <i>t</i>		Web Width <i>W</i>		HOLE	WGT
	In.	mm.	In.	mm.	In.	mm.	In.	mm.	In.	mm.		
1/2	0.84	21	2.00	51	2.62	67	0.62	16	1.50	38	0.62	2.0
3/4	1.05	27	2.50	64	3.25	83	0.75	19	1.75	44	0.75	3.0
1	1.32	34	2.75	70	3.50	89	0.75	19	2.00	51	0.75	3.0
1 1/4	1.66	42	3.12	79	3.88	99	0.88	22	2.00	51	0.75	4.0
1 1/2	1.90	48	3.56	90	4.50	114	0.88	22	2.25	57	0.88	5.0
2	2.38	60	4.25	108	5.00	127	1.00	25	2.25	57	0.75	10.0
2 1/2	2.88	73	5.00	127	5.88	149	1.12	28	2.25	57	0.88	10.0
3	3.50	89	5.75	146	6.62	168	1.12	28	2.25	57	0.88	15.0
3 1/2	4.00	102	6.25	159	7.25	184	1.12	28	2.50	64	0.88	17.5
4	4.50	114	6.88	175	7.88	200	1.25	32	2.50	64	0.88	20.0
5	5.56	141	8.25	210	9.25	235	1.38	35	2.75	70	0.88	30.0
6	6.62	168	9.50	241	10.62	270	1.38	35	3.25	83	0.88	40.0
8	8.62	219	11.88	302	13.00	330	1.62	41	3.75	95	1.00	80.0
10	10.75	273	14.00	356	15.25	387	1.75	44	4.00	102	1.12	100.0
12	12.75	324	16.25	413	17.75	451	2.00	51	4.75	121	1.25	150.0
14	14.00	356	18.00	457	20.25	514	2.12	54	5.00	127	1.25	200.0
16	16.00	406	20.00	508	22.50	572	2.25	57	5.00	127	1.38	250.0
18	18.00	457	22.62	575	24.75	629	2.38	60	5.00	127	1.38	350.0
20	20.00	508	25.00	635	27.00	686	2.75	70	5.00	127	1.38	500.0
24	24.00	610	29.50	749	32.00	813	3.12	79	6.00	152	1.62	800.0

Note: 1. Hole size (where required due to bolt spacing) shall be the same as the flange bolt hole.

Note: 1. Female ring joint groove dimensions shall be designed for octagonal rings in accordance with ANSI B16.5.

RING TYPE JOINTS

Dimensions of Class 600 Female Ring-Joint Facing Figure 8 Blanks

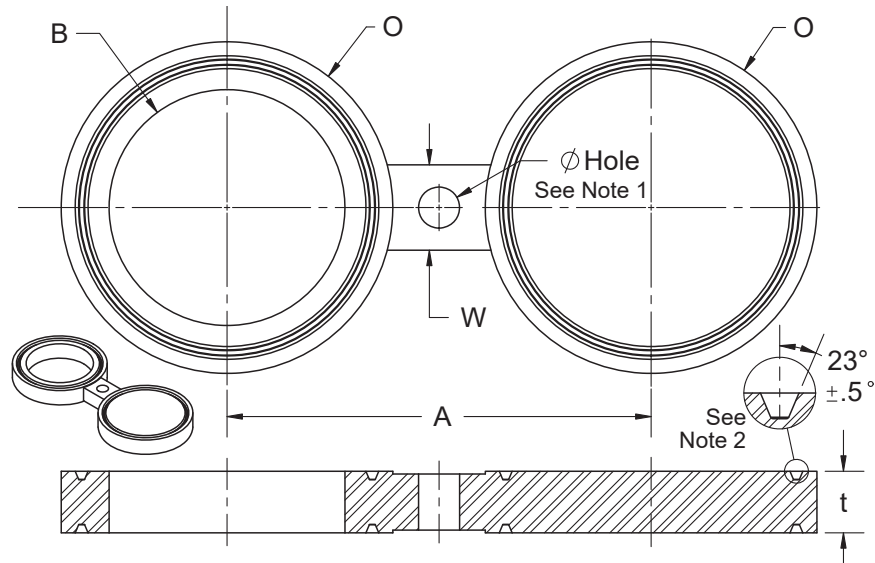

NPS	Inside Diameter <i>B</i>		Outside Diameter <i>O</i>		Centerline Dimension <i>A</i>		Thickness <i>t</i>		Web Width <i>W</i>		HOLE	WGT
	In.	mm.	In.	mm.	In.	mm.	In.	mm.	In.	mm.		
1/2	0.84	21	2.00	51	2.62	67	0.75	19	1.50	38	0.62	2.0
3/4	1.05	27	2.50	64	3.25	83	0.88	22	1.75	44	0.75	3.0
1	1.32	34	2.75	70	3.50	89	0.88	22	2.00	51	0.75	3.0
1 1/4	1.66	42	3.12	79	3.88	99	0.88	22	2.00	51	0.75	4.0
1 1/2	1.90	48	3.56	90	4.50	114	0.88	22	2.25	57	0.88	5.0
2	2.38	60	4.25	108	5.00	127	1.12	28	2.25	57	0.75	10.0
2 1/2	2.88	73	5.00	127	5.88	149	1.25	32	2.25	57	0.88	10.0
3	3.50	89	5.75	146	6.62	168	1.25	32	2.25	57	0.88	15.0
3 1/2	4.00	102	6.25	159	7.25	184	1.38	35	2.50	64	1.00	17.5
4	4.50	114	6.88	175	8.50	216	1.38	35	2.50	64	1.00	20.0
5	5.56	141	8.25	210	10.50	267	1.50	38	2.75	70	1.12	30.0
6	6.62	168	9.50	241	11.50	292	1.75	44	3.25	83	1.12	40.0
8	8.62	219	11.88	302	13.75	349	2.00	51	3.75	95	1.25	80.0
10	10.75	273	14.00	356	17.00	432	2.25	57	4.00	102	1.38	130.0
12	12.75	324	16.25	413	19.25	489	2.50	64	4.75	121	1.38	200.0
14	14.00	356	18.00	457	20.75	527	2.62	67	5.00	127	1.50	250.0
16	16.00	406	20.00	508	23.75	603	2.88	73	5.00	127	1.62	350.0
18	18.00	457	22.62	575	25.75	654	3.12	79	5.00	127	1.75	500.0
20	20.00	508	25.00	635	28.50	724	3.50	89	5.00	127	1.75	650.0
24	24.00	610	29.50	749	33.00	838	4.12	105	6.00	152	2.00	1000.0

Note: 1. Hole size (where required due to bolt spacing) shall be the same as the flange bolt hole.

Note: 1. Female ring joint groove dimensions shall be designed for octagonal rings in accordance with ANSI B16.5.

RING TYPE JOINTS

Dimensions of Class 900 Female Ring-Joint Facing Figure 8 Blanks

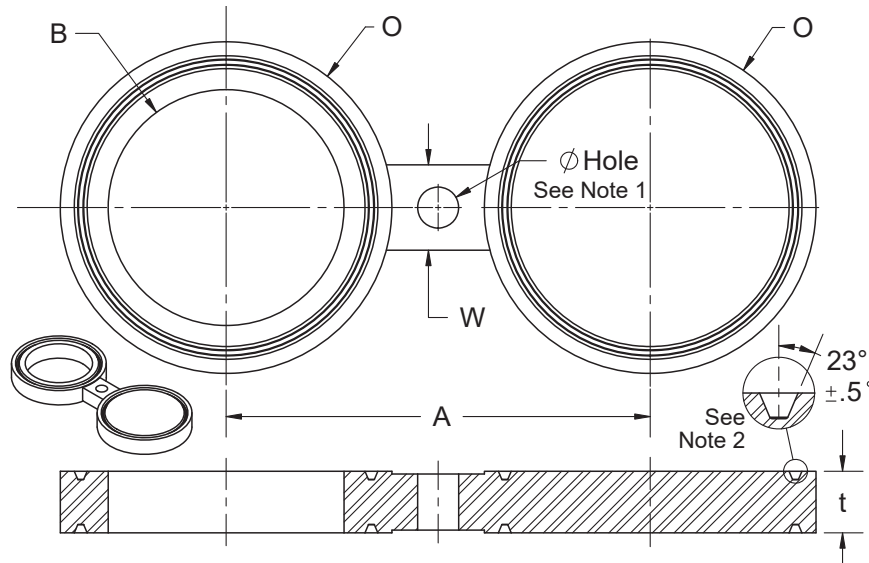

NPS	Inside Diameter <i>B</i>		Outside Diameter <i>O</i>		Centerline Dimension <i>A</i>		Thickness <i>t</i>		Web Width <i>W</i>		HOLE	WGT
	In.	mm.	In.	mm.	In.	mm.	In.	mm.	In.	mm.		
1/2	0.84	21	2.38	60	3.25	83	0.88	22	1.50	38	0.88	3.0
3/4	1.05	27	2.62	67	3.50	89	0.88	22	1.75	44	0.88	4.0
1	1.32	34	2.81	71	4.00	102	0.88	22	2.00	51	1.00	5.0
1 1/4	1.66	42	3.19	81	4.38	111	1.00	25	2.00	51	1.00	5.0
1 1/2	1.90	48	3.62	92	4.88	124	1.00	25	2.50	64	1.12	5.0
2	2.38	60	4.88	124	6.50	165	1.25	32	2.00	51	1.00	10.0
2 1/2	2.88	73	5.38	137	7.50	190	1.38	35	2.62	67	1.12	15.0
3	3.50	89	6.12	156	7.50	190	1.38	35	2.62	67	1.00	20.0
4	4.50	114	7.12	181	9.25	235	1.62	41	2.88	73	1.25	30.0
5	5.56	141	8.50	216	11.00	279	1.75	44	2.88	73	1.38	45.0
6	6.62	168	9.50	241	12.50	318	1.88	48	2.88	73	1.25	60.0
8	8.62	219	12.12	308	15.50	394	2.25	57	3.12	79	1.50	100.0
10	10.75	273	14.25	362	18.50	470	2.50	64	4.75	121	1.50	150.0
12	12.75	324	16.50	419	21.00	533	2.88	73	4.75	121	1.50	250.0
14	14.00	356	18.38	467	22.00	559	3.25	83	4.75	121	1.62	250.0
16	16.00	406	20.62	524	24.25	616	3.62	92	5.00	127	1.75	450.0
18	18.00	457	23.38	594	27.00	686	4.00	102	5.25	133	2.00	700.0
20	20.00	508	25.50	648	29.50	749	4.38	111	5.00	127	2.12	900.0
24	24.00	610	30.38	772	35.50	902	5.25	133	5.50	140	2.62	1100.0

Note: 1. Hole size (where required due to bolt spacing) shall be the same as the flange bolt hole.

Note: 1. Female ring joint groove dimensions shall be designed for octagonal rings in accordance with ANSI B16.5.

RING TYPE JOINTS

Dimensions of Class 1500 Female Ring-Joint Facing Figure 8 Blanks

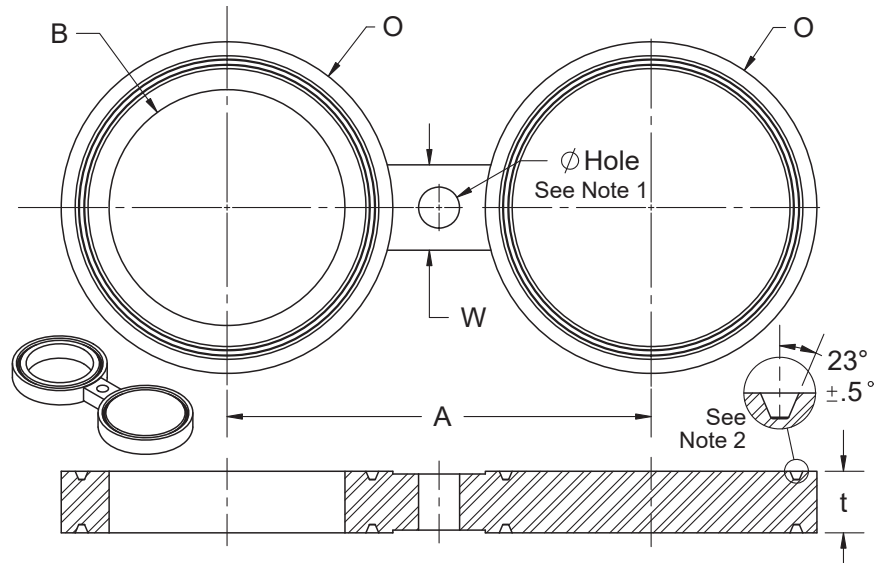

NPS	Inside Diameter <i>B</i>		Outside Diameter <i>O</i>		Centerline Dimension <i>A</i>		Thickness <i>t</i>		Web Width <i>W</i>		HOLE	WGT
	In.	mm.	In.	mm.	In.	mm.	In.	mm.	In.	mm.		
1/2	0.84	21	2.38	60	3.25	83	0.88	22	1.50	38	0.88	2.1
3/4	1.05	27	2.62	67	3.50	89	1.00	25	1.75	44	0.88	2.8
1	1.32	34	2.81	71	4.00	102	1.00	25	2.12	54	1.00	3.1
1 1/4	1.66	42	3.19	81	4.38	111	1.00	25	2.12	54	1.00	3.9
1 1/2	1.90	48	3.62	92	4.88	124	1.12	28	2.25	57	1.12	5.6
2	2.38	60	4.88	124	6.50	165	1.38	35	2.12	54	1.00	12.9
2 1/2	2.88	73	5.38	137	7.50	190	1.50	38	2.25	57	1.12	16.6
3	3.50	89	6.62	168	8.00	203	1.75	44	2.88	73	1.25	29.0
4	4.50	114	7.62	194	9.50	241	1.88	48	3.00	76	1.38	40.0
5	5.56	141	9.00	229	11.50	292	2.12	54	3.00	76	1.62	62.0
6	6.62	168	9.75	248	12.50	318	2.38	60	3.12	79	1.50	78.0
8	8.62	219	12.50	318	15.50	394	2.88	73	3.38	86	1.75	153.0
10	10.75	273	14.62	371	19.00	483	3.25	83	5.25	133	2.00	226.0
12	12.75	324	17.25	438	22.50	572	4.00	102	5.25	133	2.12	385.0
14	14.00	356	19.25	489	25.00	635	4.38	111	5.50	140	2.38	532.0
16	16.00	406	21.50	546	27.75	705	4.88	124	5.75	146	2.62	727.0
18	18.00	457	24.12	613	30.50	775	5.25	133	6.00	152	2.88	982.0
20	20.00	508	26.50	673	32.75	832	5.62	143	6.50	165	3.12	1258.0
24	24.00	610	31.25	772	39.00	991	6.62	168	7.00	179	3.62	2031.0

Note: 1. Hole size (where required due to bolt spacing) shall be the same as the flange bolt hole.

Note: 1. Female ring joint groove dimensions shall be designed for octagonal rings in accordance with ANSI B16.5.

RING TYPE JOINTS

Dimensions of Class 2500 Female Ring-Joint Facing Figure 8 Blanks

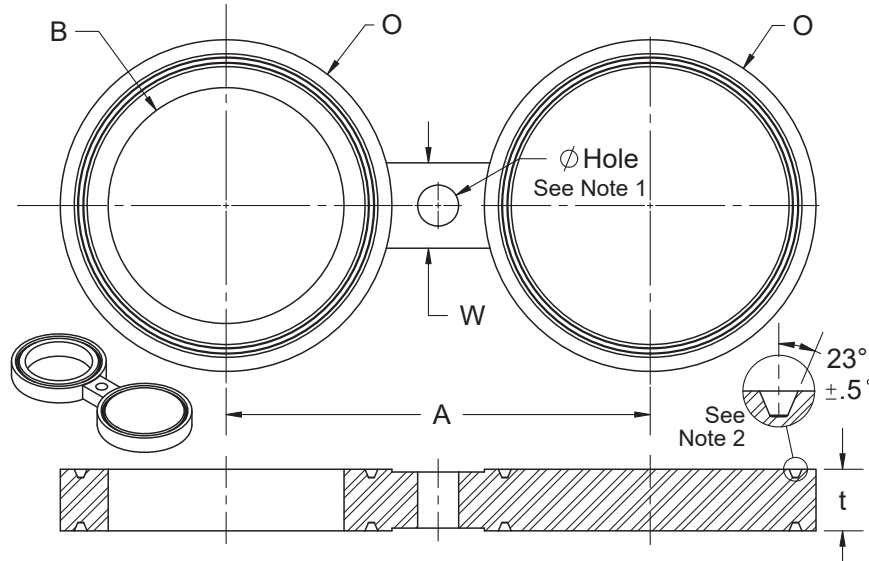

NPS	Inside Diameter <i>B</i>		Outside Diameter <i>O</i>		Centerline Dimension <i>A</i>		Thickness <i>t</i>		Web Width <i>W</i>		HOLE	WGT
	In.	mm.	In.	mm.	In.	mm.	In.	mm.	In.	mm.		
1/2	0.84	21	2.56	65	3.50	89	1.00	25	1.50	38	0.88	2.8
3/4	1.05	27	2.88	73	3.75	95	1.12	28	1.75	44	0.88	3.9
1	1.32	34	3.25	83	4.25	108	1.12	28	2.12	54	1.00	4.8
1 1/4	1.66	42	4.00	102	5.12	130	1.38	35	2.12	54	1.12	9.0
1 1/2	1.90	48	4.50	114	5.75	146	1.50	38	2.38	60	1.25	12.3
2	2.38	60	5.25	133	6.75	171	1.62	41	2.25	57	1.12	17.8
2 1/2	2.88	73	5.88	149	7.75	197	1.88	48	2.38	60	1.25	25.5
3	3.50	89	6.62	168	9.00	229	2.00	51	3.00	76	1.38	34.0
4	4.50	114	8.00	203	10.75	273	2.50	64	3.25	83	1.62	60.0
5	5.56	141	9.50	241	12.75	324	2.88	73	3.50	89	1.88	73.0
6	6.62	168	11.00	279	14.50	368	3.25	83	3.75	95	2.12	143.0
8	8.62	219	13.38	340	17.25	438	3.88	99	3.75	95	2.12	245.0
10	10.75	273	16.75	425	21.25	540	4.62	117	3.58	91	2.62	459.0
12	12.75	324	19.50	495	24.38	619	5.25	133	6.00	152	2.88	699.0

Note: 1. Hole size (where required due to bolt spacing) shall be the same as the flange bolt hole.

Note: 1. Female ring joint groove dimensions shall be designed for octagonal rings in accordance with ANSI B16.5.

Dimensions of Class 150 Blind and Spacer

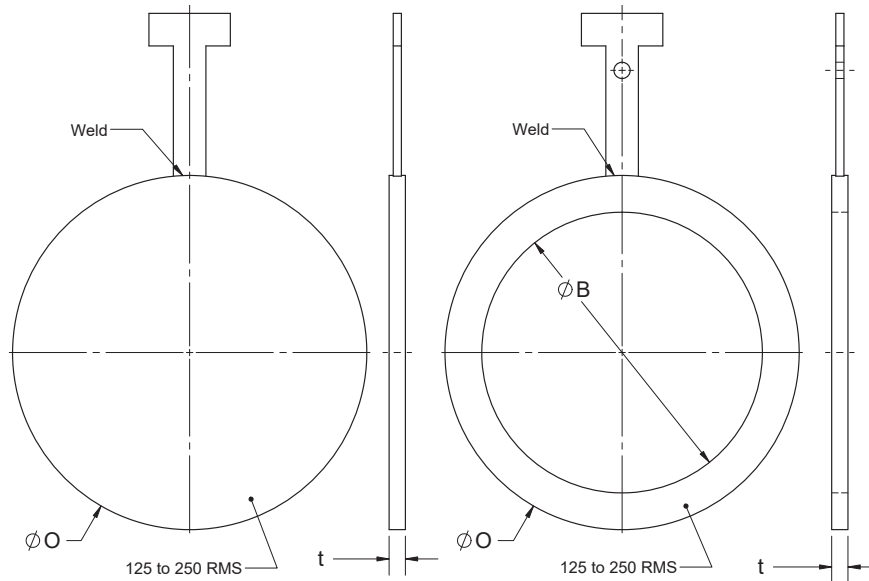

ASME B16.48 BLINDS AND SPACERS

NPS	Inside Diameter B		Outside Diameter O		Thk t		Bld Wgt	Spr Wgt
	In.	mm.	In.	mm.	In.	mm.		
1/2	0.62	16	1.75	44	0.12	3	0.2	0.1
3/4	0.82	21	2.12	54	0.12	3	0.2	0.1
1	1.05	27	2.50	64	0.12	3	0.2	0.1
1 1/4	1.66	42	2.88	73	0.25	6	0.5	0.2
1 1/2	1.90	48	3.25	83	0.25	6	0.6	0.3
2	2.38	60	4.00	102	0.25	6	0.6	0.3
2 1/2	2.88	73	4.75	121	0.25	6	1.2	0.6
3	3.50	89	5.25	133	0.25	6	1.8	0.9
3 1/2	4.00	102	6.25	159	0.38	10	2.2	1.1
4	4.50	114	6.75	171	0.38	10	2.6	1.3
5	5.56	141	7.62	194	0.38	10	4.4	2.2
6	6.62	168	8.62	219	0.50	13	6.2	3.1
8	8.62	219	10.88	276	0.50	13	12.7	6.4
10	10.75	273	13.25	337	0.62	16	21.1	10.6
12	12.75	324	16.00	406	0.75	19	37.3	18.6
14	14.00	356	17.62	448	0.75	19	52.6	26.3
16	16.00	406	20.12	511	0.88	22	76.6	38.3
18	18.00	457	21.50	546	1.00	25	92	46
20	20.00	508	23.75	603	1.12	28	118	59
24	24.00	610	28.12	714	1.25	32	203	102

Dimensions of Class 300 Blind and Spacer

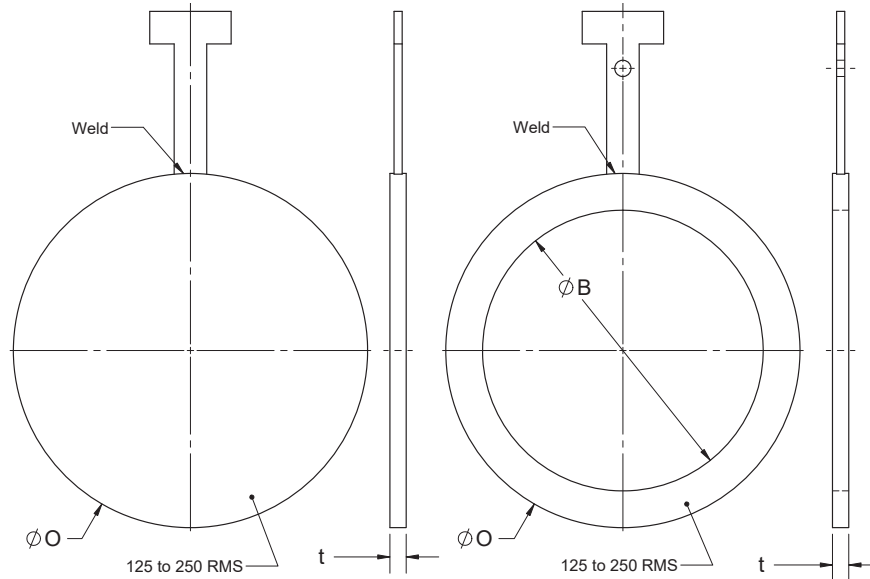

ASME B16.48 BLINDS AND SPACERS

NPS	Inside Diameter B		Outside Diameter O		Thk t		Bld Wgt	Spr Wgt
	In.	mm.	In.	mm.	In.	mm.		
1/2	0.62	16	2.00	51	0.25	6	0.33	0.17
3/4	0.82	21	2.50	64	0.25	6	0.33	0.17
1	1.05	27	2.75	70	0.25	6	0.33	0.17
1 1/4	1.66	42	3.12	79	0.25	6	0.6	0.3
1 1/2	1.90	48	3.62	92	0.25	6	0.87	0.43
2	2.38	60	4.25	108	0.38	10	1.2	0.6
2 1/2	2.88	73	5.00	127	0.38	10	1.6	0.8
3	3.50	89	5.75	146	0.38	10	1.93	0.97
3 1/2	4.00	102	6.38	162	0.50	13	3.6	1.8
4	4.50	114	7.00	178	0.50	13	5.19	2.6
5	5.56	141	8.38	213	0.62	16	9.32	4.66
6	6.62	168	9.75	248	0.62	16	13.39	6.69
8	8.62	219	12.00	305	0.88	22	26.64	13.32
10	10.75	273	14.12	359	1.00	25	43.29	21.65
12	12.75	324	16.50	419	1.12	28	68.6	34.3
14	14.00	356	19.00	483	1.25	32	101.9	50.95
16	16.00	406	21.12	537	1.50	38	143.2	71.6
18	18.00	457	23.38	594	1.62	41	196.5	98.24
20	20.00	508	25.62	651	1.75	44	249	124.5
24	24.00	610	30.38	772	2.00	51	416.3	208.1

Dimensions of Class 600 Blind and Spacer

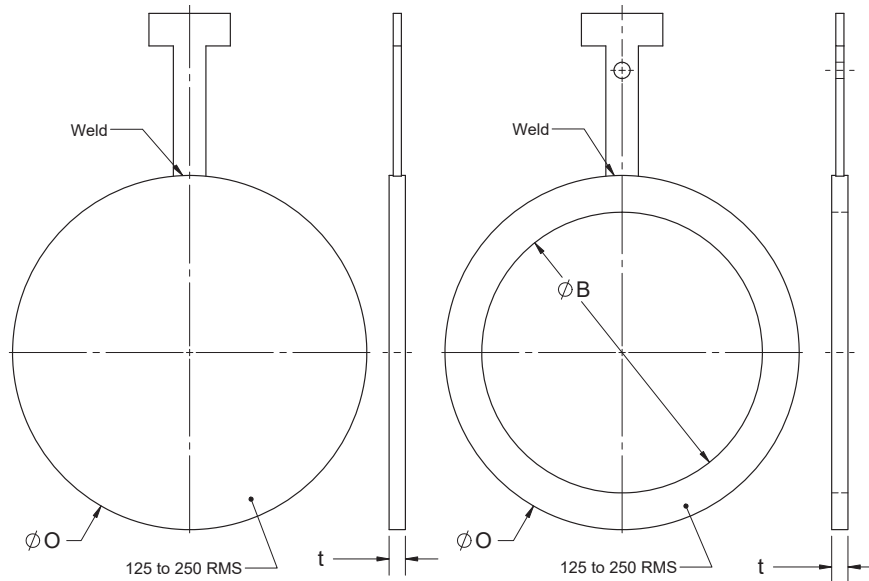

ASME B16.48 BLINDS AND SPACERS

NPS	Inside Diameter B		Outside Diameter O		Thk t		Bld Wgt	Spr Wgt
	In.	mm.	In.	mm.	In.	mm.		
1/2	0.62	16	2.00	51	0.25	6	0.33	0.165
3/4	0.82	21	2.50	64	0.25	6	0.33	0.17
1	1.05	27	2.75	70	0.25	6	0.53	0.27
1 1/4	1.44	37	3.12	79	0.38	10	0.73	0.37
1 1/2	1.68	43	3.62	92	0.38	10	0.87	0.43
2	2.16	55	4.25	108	0.38	10	1.47	0.73
2 1/2	2.64	67	5.00	127	0.50	13	2.6	1.3
3	3.26	83	5.75	146	0.50	13	3.66	1.83
3 1/2	3.76	96	6.25	159	0.62	16	5.86	2.93
4	4.26	108	7.50	191	0.62	16	7.99	4
5	5.30	135	9.38	238	0.75	19	15.65	7.83
6	6.36	162	10.38	264	0.88	22	23.31	11.66
8	8.33	212	12.50	318	1.12	28	39.96	19.98
10	10.42	265	15.62	397	1.38	35	78.26	39.13
12	12.39	315	17.88	454	1.62	41	123.2	61.61
14	13.62	346	19.25	489	1.75	44	153.2	76.59
16	15.62	397	22.12	562	2.00	51	226.4	113.2
18	17.62	448	24.00	610	2.12	54	299.7	149.9
20	19.56	497	26.75	679	2.50	64	412.9	206.5
24	23.50	597	31.00	787	2.88	73	649.4	324.7

Dimensions of Class 900 Blind and Spacer

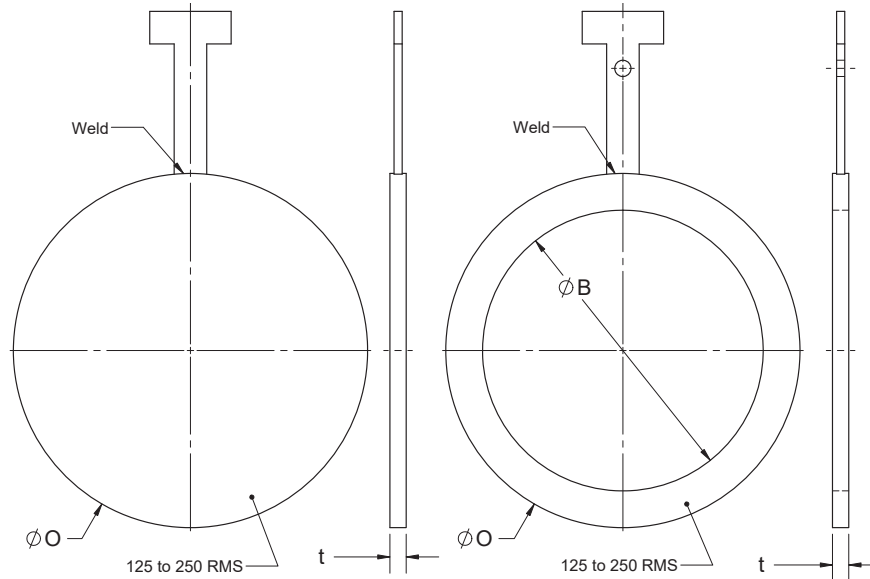

ASME B16.48 BLINDS AND SPACERS

NPS	Inside Diameter B		Outside Diameter O		Thk t		Blid Wgt	Spr Wgt
	In.	mm.	In.	mm.	In.	mm.		
1/2	0.62	16	2.38	60	0.25	6	0.33	0.17
3/4	0.82	21	2.62	67	0.25	6	0.33	0.17
1	1.05	27	3.00	76	0.25	6	0.6	0.3
1 1/4	1.44	35	3.38	86	0.38	10	0.93	0.47
1 1/2	1.68	41	3.75	95	0.38	10	1.2	0.6
2	2.16	53	5.50	140	0.50	13	3.13	1.57
2 1/2	2.64	63	6.38	162	0.50	13	4.73	2.36
3	3.26	78	6.50	165	0.62	16	6.33	3.16
4	4.26	102	8.00	203	0.75	19	11.32	5.66
5	5.30	128	9.62	244	0.88	22	23.18	11.59
6	6.36	154	11.25	286	1.00	25	34.97	17.48
8	8.33	203	14.00	356	1.38	35	64.6	32.3
10	10.42	255	17.00	432	1.62	41	118.6	59.27
12	12.39	303	19.50	495	1.88	48	186.5	93.24
14	13.62	333	20.38	518	2.12	54	203.1	101.6
16	15.62	381	22.50	572	2.38	60	273.1	136.5
18	17.62	429	25.00	635	2.62	67	379	189.8
20	19.56	478	27.38	695	2.88	73	499.5	249.8
24	23.50	575	32.88	835	3.50	89	832.5	416.3

Dimensions of Class 1500 Blind and Spacer

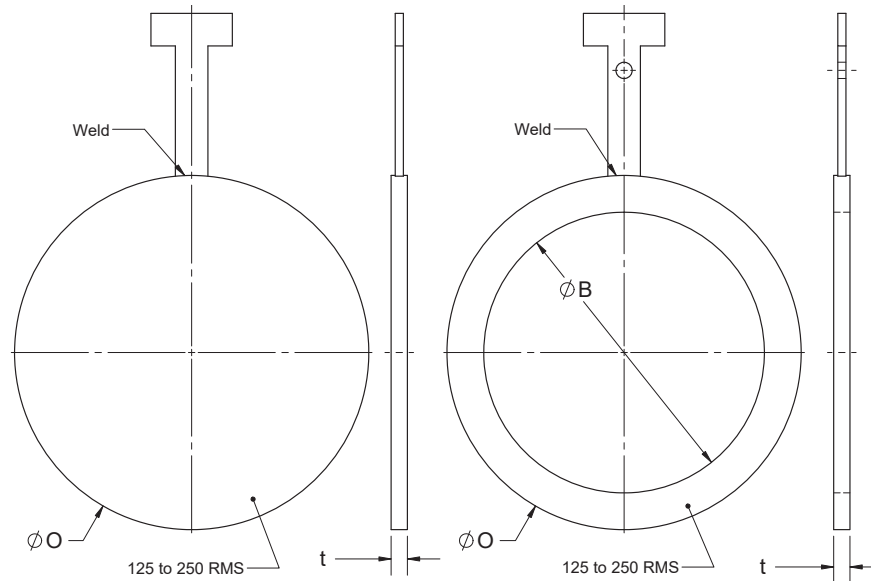

ASME B16.48 BLINDS AND SPACERS

NPS	Inside Diameter B		Outside Diameter O		Thk t		Bld Wgt	Spr Wgt
	In.	mm.	In.	mm.	In.	mm.		
1/2	0.62	16	2.38	60	0.25	6	0.4	0.2
3/4	0.82	21	2.62	67	0.38	10	0.73	0.37
1	1.05	27	3.00	76	0.38	10	0.93	0.47
1 1/4	1.38	37	3.38	86	0.38	10	1.2	0.6
1 1/2	1.61	43	3.75	95	0.50	13	1.86	0.93
2	2.07	55	5.50	140	0.50	13	4.2	2.1
2 1/2	2.47	67	6.38	162	0.62	16	6.93	3.46
3	3.07	83	6.75	171	0.75	19	9.32	4.66
4	4.03	108	8.12	206	0.88	22	14.65	7.33
5	5.05	135	9.88	251	1.12	28	27.97	13.99
6	6.06	162	11.00	279	1.38	35	41.96	20.98
8	7.98	212	13.75	349	1.62	41	75.26	37.63
10	10.02	265	17.00	432	2.00	51	141.9	70.93
12	11.94	315	20.38	518	2.38	60	176.5	88.25
14	13.12	346	22.62	575	2.62	67	331	165.5
16	15.00	397	25.12	638	3.00	76	461.5	230.8
18	16.88	448	27.62	702	3.38	86	622	311
20	18.81	497	29.62	752	3.75	95	779.2	389.6
24	22.62	597	35.38	899	4.38	111	1030	515.2

Dimensions of Class 2500 Blind and Spacer

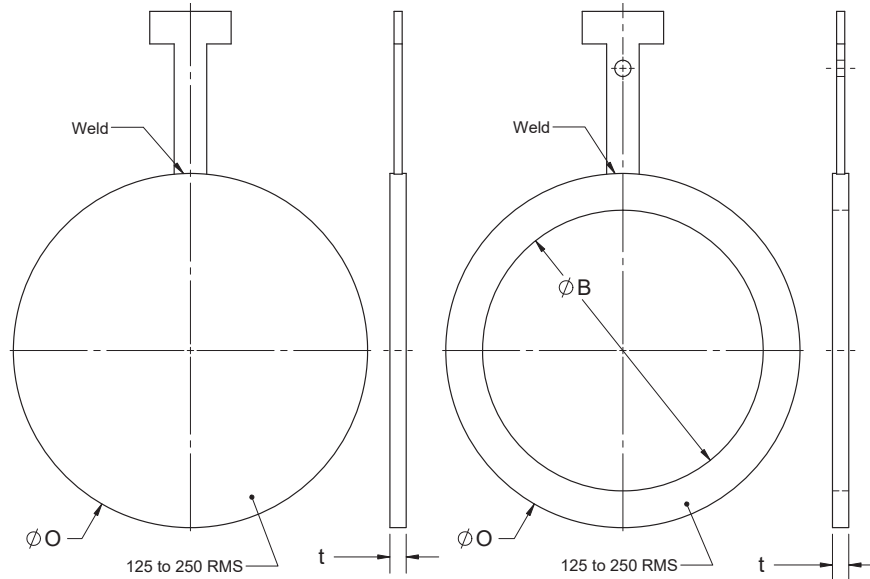

ASME B16.48 BLINDS AND SPACERS

NPS	Inside Diameter B		Outside Diameter O		Thk t		Bld Wgt	Spr Wgt
	In.	mm.	In.	mm.	In.	mm.		
1/2	0.62	16	2.62	67	0.38	10	0.73	0.37
3/4	0.82	21	2.88	73	0.38	10	0.87	0.43
1	1.05	27	3.25	83	0.38	10	1.13	0.57
1 1/4	1.38	35	4.00	102	0.50	13	2.26	1.13
1 1/2	1.61	41	4.50	114	0.62	16	3.46	1.73
2	2.07	53	5.62	143	0.62	16	5.39	2.7
2 1/2	2.47	63	6.50	165	0.75	19	8.72	4.36
3	3.07	78	7.62	194	0.88	22	13.99	6.99
4	4.03	102	9.12	232	1.12	28	24.64	12.32
5	5.05	128	10.88	276	1.38	35	43.29	21.65
6	6.06	154	12.38	314	1.62	41	64.6	32.3
8	7.81	198	15.12	384	2.12	54	124.5	62.27
10	9.75	248	18.62	473	2.62	67	232.4	116.2
12	11.37	289	21.50	546	3.12	79	368.3	184.2

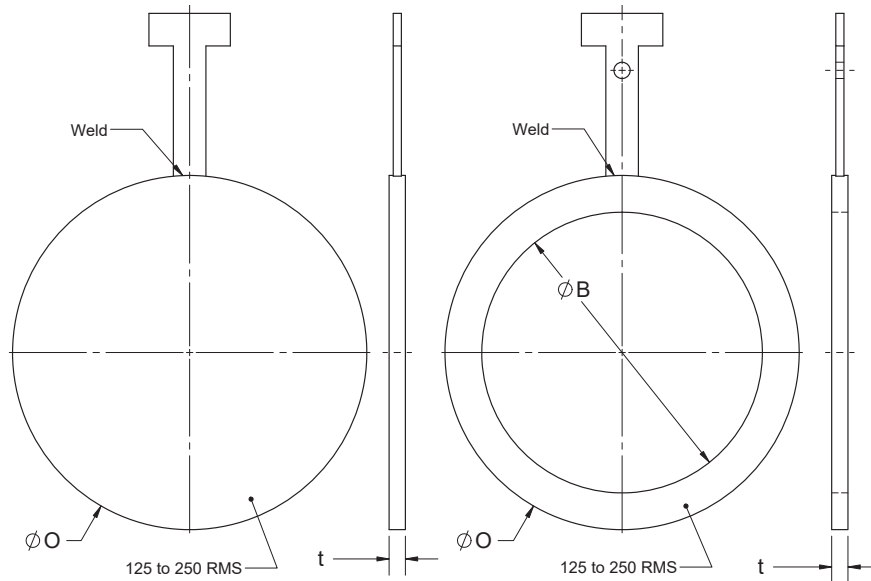

A516 GR70N TO SUIT ASME B16.47 SERIES A FLANGES

PIPE SIZE	CLASS 150			CLASS 300			CLASS 600		
	THK	OD	ID	THK	OD	ID	THK	OD	ID
26	1.75	30.375	25.25	2.063	32.75	25.25	2.875	34	25.25
28	1.75	32.625	27.25	2.125	35.25	27.25	3	35.875	27.25
30	1.75	34.625	29.25	2.375	37.375	29.25	3.375	38.125	29.25
32	1.75	36.875	31.25	2.5	39.5	31.25	3.5	40.125	31.25
34	2	38.875	33.25	2.625	41.5	33.25	3.75	42.125	33.25
36	2	41.125	35.25	3	43.875	35.25	4	44.375	35.25
38	2	43.625	37.25	3	41.375	37.25	4.125	43.375	37.25
40	2	45.625	39.25	3.125	43.75	39.25	4.375	45.375	39.25
42	2.25	47.875	41	3.25	45.75	41	4.5	47.875	41
44	2.25	50.125	43	3.5	47.875	43	4.75	49.375	43
46	2.5	52.125	45	3.625	50	45	5	52.125	45
48	2.5	54.375	47	3.75	52	47	5.375	54.625	47
50	2.5	56.375	49	4	54.125	49	5.5	56.875	49
52	2.75	58.375	51	4	56.125	51	5.75	58.875	51
54	2.75	60.875	53	4.25	58.625	53	5.875	61.125	53
56	2.875	63.125	55	4.375	60.625	55	6.125	63.375	55
58	2.875	65.375	57	4.5	62.625	57	6.375	65.375	57
60	3.125	67.375	59	4.625	64.625	59	6.5	68.125	59

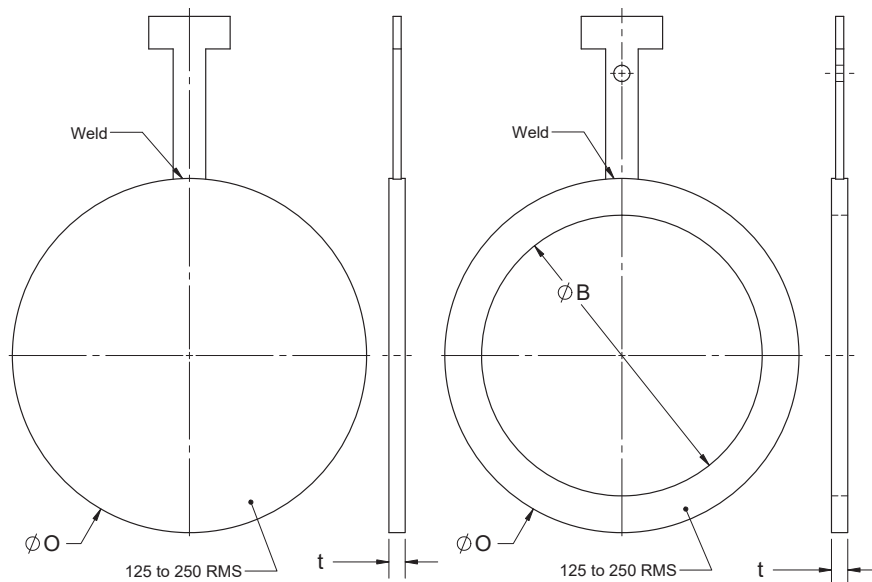

A516 GR70N TO SUIT ASME B16.47 SERIES B FLANGES

PIPE SIZE	CLASS 150			CLASS 300			CLASS 600		
	THK	OD	ID	THK	OD	ID	THK	OD	ID
26	1.75	28.438	25.25	2.063	30.25	25.25	2.875	30	25.25
28	1.75	30.437	27.25	2.125	32.375	27.25	3	32.125	27.25
30	1.75	32.437	29.25	2.375	34.75	29.25	3.375	34.5	29.25
32	1.75	34.56	31.25	2.5	36.875	31.25	3.5	36.625	31.25
34	2	36.69	33.25	2.625	39	33.25	3.75	39.125	33.25
36	2	38.75	35.25	3	41.125	35.25	4	41.25	35.25
38	2	41	37.25	3	43.125	37.25			
40	2	43	39.25	3.125	45.125	39.25			
42	2.25	45	41	3.25	47.125	41			
44	2.25	47	43	3.5	49.125	43			
46	2.5	49.31	45	3.625	51.75	45			
48	2.5	51.312	47	3.75	53.75	47			
50	2.5	53.312	49	4	55.75	49			
52	2.75	55.312	51	4	57.75	51			
54	2.75	57.5	53	4.25	60.125	53			
56	2.875	59.5	55	4.375	62.625	55			
58	2.875	62.062	57	4.5	65.065	57			
60	3.125	64.062	59	4.625	67.065	59			

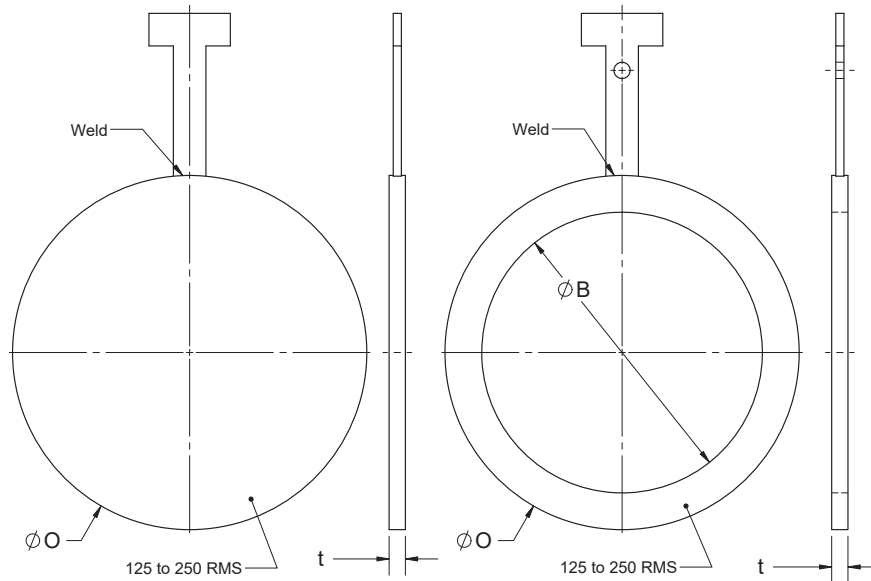

A316 TO SUIT ASME B16.47 SERIES A FLANGES

PIPE SIZE	CLASS 150			CLASS 300			CLASS 600		
	THK	OD	ID	THK	OD	ID	THK	OD	ID
26	1.5	30.375	25.25	2.250	32.75	25.25	3	34	25.25
28	1.75	32.625	27.25	2.375	35.25	27.25	3.25	35.875	27.25
30	1.75	34.625	29.25	2.5	37.375	29.25	3.5	38.125	29.25
32	1.75	36.875	31.25	2.75	39.5	31.25	3.75	40.125	31.25
34	2	38.875	33.25	2.875	41.5	33.25	4	42.125	33.25
36	2	41.125	35.25	3	43.875	35.25	4.25	44.375	35.25
38	2	43.625	37.25	3.25	41.375	37.25	4.5	43.375	37.25
40	2.125	45.625	39.25	3.375	43.75	39.25	4.75	45.375	39.25
42	2.25	47.875	41	3.5	45.75	41	5	47.875	41
44	2.25	50.125	43	3.75	47.875	43	5.125	49.375	43
46	2.5	52.125	45	3.875	50	45	5.375	52.125	45
48	2.5	54.375	47	4.125	52	47	5.75	54.625	47
50	2.625	56.375	49	4.125	54.125	49	5.875	56.875	49
52	2.75	58.375	51	4.375	56.125	51	6.125	58.875	51
54	2.875	60.875	53	4.5	58.625	53	6.375	61.125	53
56	2.875	63.125	55	4.75	60.625	55	6.5	63.375	55
58	3	65.375	57	4.875	62.625	57	6.75	65.375	57
60	3.125	67.375	59	5	64.625	59	7	68.125	59

Dimensions of Class 900 Bind and Spacer

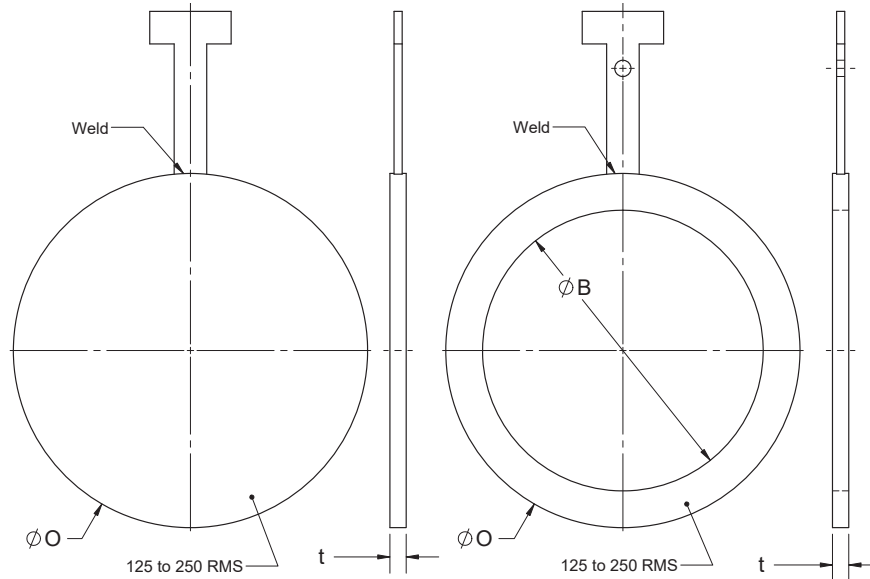

A316 TO SUIT ASME B16.47 SERIES B FLANGES

PIPE SIZE	CLASS 150			CLASS 300			CLASS 600		
	THK	OD	ID	THK	OD	ID	THK	OD	ID
26	1.5	28.438	25.25	2.250	30.25	25.25	3	30	25.25
28	1.75	30.437	27.25	2.375	32.375	27.25	3.25	32.125	27.25
30	1.75	32.437	29.25	2.5	34.75	29.25	3.5	34.5	29.25
32	1.75	34.56	31.25	2.75	36.875	31.25	3.75	36.625	31.25
34	2	36.69	33.25	2.875	39	33.25	4	39.125	33.25
36	2	38.75	35.25	3	41.125	35.25	4.25	41.25	35.25
38	2	41	37.25	3.25	43.125	37.25			
40	2.125	43	39.25	3.375	45.125	39.25			
42	2.25	45	41	3.5	47.125	41			
44	2.25	47	43	3.75	49.125	43			
46	2.5	49.31	45	3.875	51.75	45			
48	2.5	51.312	47	4.125	53.75	47			
50	2.625	53.312	49	4.125	55.75	49			
52	2.75	55.312	51	4.375	57.75	51			
54	2.875	57.5	53	4.5	60.125	53			
56	2.875	59.5	55	4.75	62.625	55			
58	3	62.062	57	4.875	65.065	57			
60	3.125	64.062	59	5	67.065	59			

VENTED SINGLE BLINDS

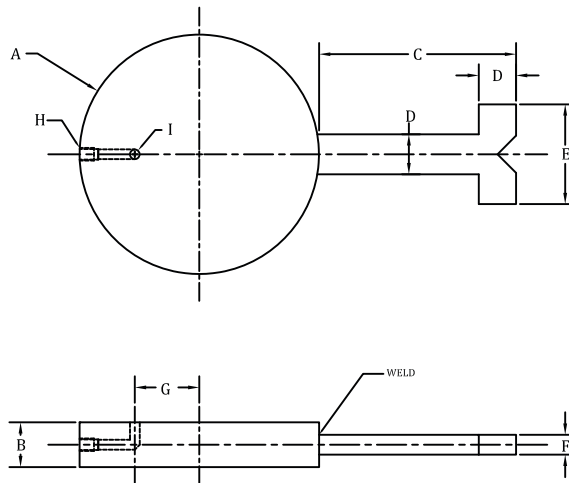

CLASS 150

NOMINAL	A	B	C	D	E	F	G	H	I
2"	4.00	1.25	4.00	0.75	2.00	0.25	0.78	0.50	0.375
3"	5.25	1.25	4.00	0.75	2.00	0.25	1.26	0.50	0.375
4"	6.75	1.25	4.00	0.75	2.00	0.25	1.72	0.50	0.375
6"	8.62	1.25	5.50	1.00	2.50	0.38	2.69	0.50	0.375
8"	10.88	1.25	5.50	1.00	2.50	0.38	3.62	0.50	0.375
10"	13.25	1.25	5.50	1.00	2.50	0.38	4.59	0.50	0.375
12"	16.00	1.25	7.00	1.50	3.00	0.50	5.50	0.50	0.375
14"	17.62	1.25	7.00	1.50	3.00	0.50	6.06	0.50	0.375
16"	20.12	1.25	7.00	1.50	3.00	0.50	6.47	0.50	0.375
18"	21.50	1.25	7.00	1.50	3.00	0.50	7.87	0.50	0.375
20"	23.75	1.25	7.00	1.50	3.00	0.50	8.78	0.50	0.375
24"	28.12	1.25	7.00	1.50	3.00	0.50	10.59	0.50	0.375

NOTE:

- DIMENSION "G" REFLECTS THE USE OF SCH 80 PIPE. END USER TO REVIEW AND CONFIRM WHAT IS ACCEPTABLE FOR THE SERVICE CONDITIONS THEY ARE BEING INSTALLED INTO.
- CONFIRM PORT ORIENTATION IN REFERENCE TO THE HANDLE. IE. 90 DEG., 180 DEG.
- PORT SIZE CAN VARY, AT THE SHOWN THICKNESS A MAXIMUM OF 3/4" NOMINAL IS POSSIBLE.
- BLIND THICKNESS CAN VARY AS LONG AS IT IS NOT LESS THAN THE MINIMUM THICKNESS OUTLINED IN ASME B31.3.

VENTED SINGLE BLINDS

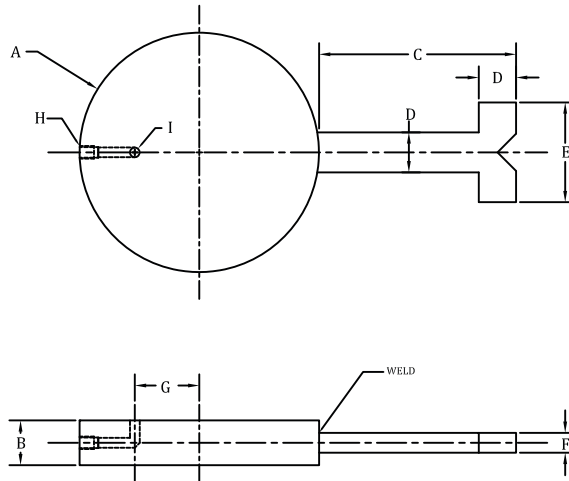

CLASS 300

NOMINAL	A	B	C	D	E	F	G	H	I
2"	4.25	1.25	4.00	0.75	2.00	0.25	0.78	0.50	0.375
3"	5.75	1.25	4.00	0.75	2.00	0.25	1.26	0.50	0.375
4"	7.00	1.25	5.50	1.00	2.50	0.38	1.72	0.50	0.375
6"	9.75	1.25	5.50	1.00	2.50	0.38	2.69	0.50	0.375
8"	12.00	1.25	5.50	1.00	2.50	0.38	3.62	0.50	0.375
10"	14.12	1.25	7.00	1.50	3.00	0.50	4.59	0.50	0.375
12"	16.50	1.25	7.00	1.50	3.00	0.50	5.50	0.50	0.375
14"	19.00	1.25	7.00	1.50	3.00	0.50	6.06	0.50	0.375
16"	21.12	1.50	7.00	1.50	3.00	0.50	6.47	0.50	0.375
18"	23.38	1.62	7.00	1.50	3.00	0.50	8.87	0.50	0.375
20"	25.62	1.75	7.00	1.50	3.00	0.50	8.78	0.50	0.375
24"	30.38	2.00	7.00	1.50	3.00	0.50	10.59	0.50	0.375

NOTE:

- DIMENSION "G" REFLECTS THE USE OF SCH 80 PIPE. END USER TO REVIEW AND CONFIRM WHAT IS ACCEPTABLE FOR THE SERVICE CONDITIONS THEY ARE BEING INSTALLED INTO.
- CONFIRM PORT ORIENTATION IN REFERENCE TO THE HANDLE. IE. 90 DEG, 180 DEG.
- PORT SIZE CAN VARY, AT THE SHOWN THICKNESS A MAXIMUM OF 3/4" NOMINAL IS POSSIBLE.
- BLIND THICKNESS CAN VARY AS LONG AS IT IS NOT LESS THAN THE MINIMUM THICKNESS OUTLINED IN ASME B31.3.

VENTED SINGLE BLINDS

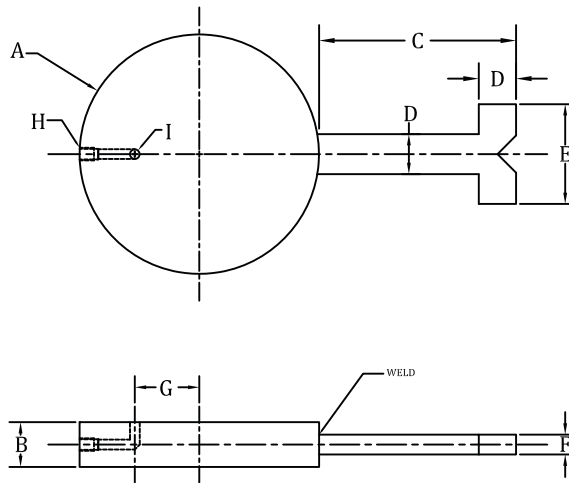

CLASS 600

NOMINAL	A	B	C	D	E	F	G	H	I
2"	4.25	1.25	4.00	0.75	2.00	0.25	0.78	0.50	0.375
3"	5.75	1.25	4.00	0.75	2.00	0.25	1.26	0.50	0.375
4"	7.50	1.25	5.50	1.00	2.50	0.38	1.72	0.50	0.375
6"	10.38	1.25	5.50	1.00	2.50	0.38	2.69	0.50	0.375
8"	12.50	1.25	5.50	1.00	2.50	0.38	3.62	0.50	0.375
10"	15.62	1.38	7.00	1.50	3.00	0.50	4.59	0.50	0.375
12"	17.88	1.62	7.00	1.50	3.00	0.50	5.50	0.50	0.375
14"	19.25	1.75	7.00	1.50	3.00	0.50	6.06	0.50	0.375
16"	22.12	2.00	7.00	1.50	3.00	0.50	6.47	0.50	0.375
18"	24.00	2.12	7.00	1.50	3.00	0.50	7.87	0.50	0.375
20"	26.75	2.50	7.00	1.50	3.00	0.50	8.78	0.50	0.375
24"	31.00	2.88	7.00	1.50	3.00	0.50	10.59	0.50	0.375

NOTE:

- DIMENSION "G" REFLECTS THE USE OF SCH 80 PIPE. END USER TO REVIEW AND CONFIRM WHAT IS ACCEPTABLE FOR THE SERVICE CONDITIONS THEY ARE BEING INSTALLED INTO.
- CONFIRM PORT ORIENTATION IN REFERENCE TO THE HANDLE. IE. 90 DEG., 180 DEG.
- PORT SIZE CAN VARY, AT THE SHOWN THICKNESS A MAXIMUM OF 3/4" NOMINAL IS POSSIBLE.
- BLIND THICKNESS CAN VARY AS LONG AS IT IS NOT LESS THAN THE MINIMUM THICKNESS OUTLINED IN ASME B31.3.

VENTED SINGLE BLINDS

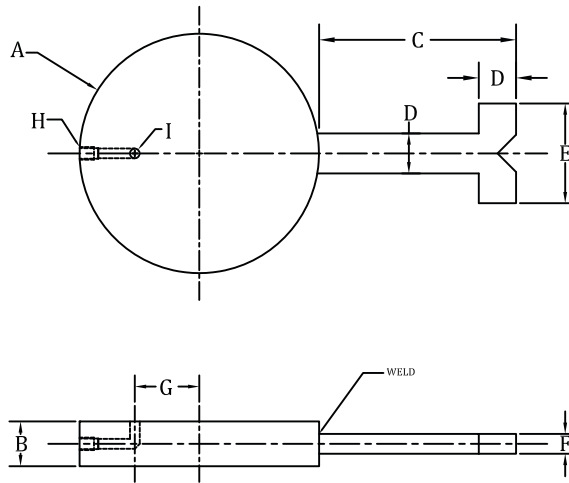

CLASS 900

NOMINAL	A	B	C	D	E	F	G	H	I
2"	5.50	1.25	4.00	0.75	2.00	0.25	0.78	0.50	0.375
3"	6.50	1.25	4.00	0.75	2.00	0.25	1.26	0.50	0.375
4"	8.00	1.25	5.50	1.00	2.50	0.38	1.72	0.50	0.375
6"	11.25	1.25	5.50	1.00	2.50	0.38	2.69	0.50	0.375
8"	14.00	1.38	5.50	1.00	2.50	0.38	3.62	0.50	0.375
10"	17.00	1.62	7.00	1.50	3.00	0.50	4.59	0.50	0.375
12"	19.50	1.88	7.00	1.50	3.00	0.50	5.50	0.50	0.375
14"	20.38	2.12	7.00	1.50	3.00	0.50	6.06	0.50	0.375
16"	22.50	2.38	7.00	1.50	3.00	0.50	6.47	0.50	0.375
18"	25.00	2.62	7.00	1.50	3.00	0.50	7.87	0.50	0.375
20"	27.38	2.88	7.00	1.50	3.00	0.50	8.78	0.50	0.375
24"	32.88	3.50	7.00	1.50	3.00	0.50	10.59	0.50	0.375

NOTE:

- DIMENSION "G" REFLECTS THE USE OF SCH 80 PIPE. END USER TO REVIEW AND CONFIRM WHAT IS ACCEPTABLE FOR THE SERVICE CONDITIONS THEY ARE BEING INSTALLED INTO.
- CONFIRM PORT ORIENTATION IN REFERENCE TO THE HANDLE. IE. 90 DEG, 180 DEG.
- PORT SIZE CAN VARY, AT THE SHOWN THICKNESS A MAXIMUM OF 3/4" NOMINAL IS POSSIBLE.
- BLIND THICKNESS CAN VARY AS LONG AS IT IS NOT LESS THAN THE MINIMUM THICKNESS OUTLINED IN ASME B31.3.

VENTED SINGLE BLINDS

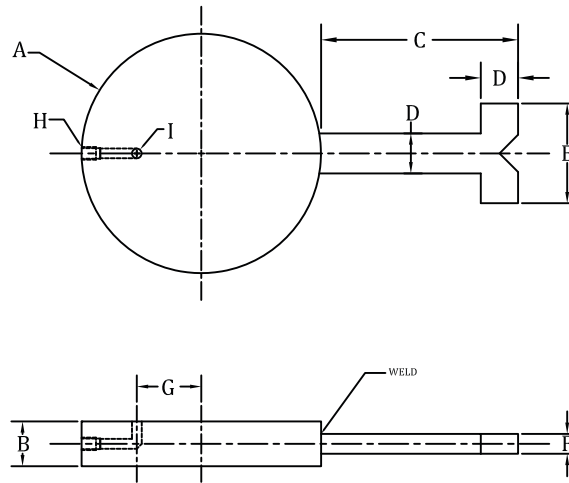

CLASS 1500

NOMINAL	A	B	C	D	E	F	G	H	I
2"	5.50	1.25	4.00	0.75	2.00	0.25	0.78	0.50	0.375
3"	6.75	1.25	4.00	0.75	2.00	0.25	1.26	0.50	0.375
4"	8.12	1.25	5.50	1.00	2.50	0.38	1.72	0.50	0.375
6"	11.00	1.38	5.50	1.00	2.50	0.38	2.69	0.50	0.375
8"	13.75	1.62	5.50	1.00	2.50	0.38	3.62	0.50	0.375
10"	17.00	2.00	7.00	1.50	3.00	0.50	4.59	0.50	0.375
12"	20.38	2.38	7.00	1.50	3.00	0.50	5.50	0.50	0.375
14"	22.62	2.62	7.00	1.50	3.00	0.50	6.06	0.50	0.375
16"	25.12	3.00	7.00	1.50	3.00	0.50	6.47	0.50	0.375
18"	27.62	3.38	7.00	1.50	3.00	0.50	7.87	0.50	0.375
20"	29.62	3.75	7.00	1.50	3.00	0.50	8.78	0.50	0.375
24"	35.38	4.38	7.00	1.50	3.00	0.50	10.59	0.50	0.375

NOTE:

- DIMENSION "G" REFLECTS THE USE OF SCH 80 PIPE. END USER TO REVIEW AND CONFIRM WHAT IS ACCEPTABLE FOR THE SERVICE CONDITIONS THEY ARE BEING INSTALLED INTO.
- CONFIRM PORT ORIENTATION IN REFERENCE TO THE HANDLE. IE. 90 DEG., 180 DEG.
- PORT SIZE CAN VARY, AT THE SHOWN THICKNESS A MAXIMUM OF 3/4" NOMINAL IS POSSIBLE.
- BLIND THICKNESS CAN VARY AS LONG AS IT IS NOT LESS THAN THE MINIMUM THICKNESS OUTLINED IN ASME B31.3.

VENTED SINGLE BLINDS

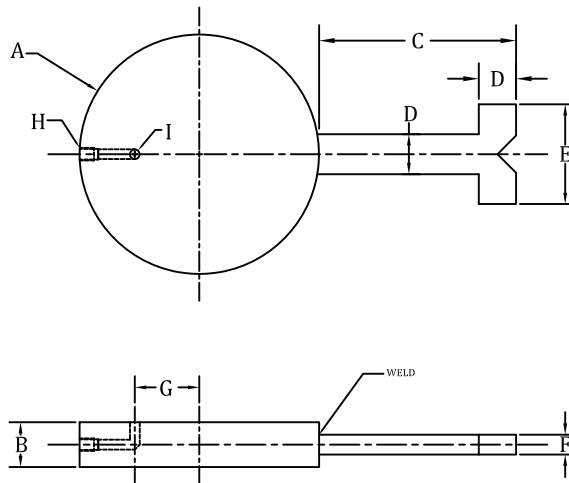

CLASS 2500

NOMINAL	A	B	C	D	E	F	G	H	I
2"	5.62	1.25	4.00	0.75	2.00	0.25	0.78	0.50	0.375
3"	7.63	1.25	4.00	0.75	2.00	0.25	1.26	0.50	0.375
4"	9.12	1.25	5.50	1.00	2.50	0.38	1.72	0.50	0.375
6"	12.38	1.62	5.50	1.00	2.50	0.38	2.69	0.50	0.375
8"	15.12	2.12	5.50	1.00	2.50	0.38	3.62	0.50	0.375
10"	18.62	2.62	7.00	1.50	3.00	0.50	4.59	0.50	0.375
12"	21.50	3.12	7.00	1.50	3.00	0.50	5.50	0.50	0.375

NOTE:

- DIMENSION "G" REFLECTS THE USE OF SCH 80 PIPE. END USER TO REVIEW AND CONFIRM WHAT IS ACCEPTABLE FOR THE SERVICE CONDITIONS THEY ARE BEING INSTALLED INTO.
- CONFIRM PORT ORIENTATION IN REFERENCE TO THE HANDLE. IE. 90 DEG., 180 DEG.
- PORT SIZE CAN VARY, AT THE SHOWN THICKNESS A MAXIMUM OF 3/4" NOMINAL IS POSSIBLE.
- BLIND THICKNESS CAN VARY AS LONG AS IT IS NOT LESS THAN THE MINIMUM THICKNESS OUTLINED IN ASME B31.3.

PADDLE TYPE ORIFICE PLATES (SERIES 520)

The Paddle type orifice plate (Series 520) is designed for use between orifice flange unions. The line size, flange rating, orifice bore, and plate material is stamped on the handle.

	125 Lbs. and 150 Lbs. A.N.S.I.	300 Lbs. A.N.S.I.	400 Lbs. A.N.S.I.	600 Lbs. A.N.S.I.	900 Lbs. A.N.S.I.	1500 Lbs. A.N.S.I.	2500 Lbs. A.N.S.I.	For All Pressure Ratings 125-1500 Lbs. A.N.S.I.		
SIZE	A	A	A	A	A	A	A	B	C	W
1/2"	1 7/8"	2 1/8"	2 1/8"	2 1/8"	2 1/2"	2 1/2"	2 3/4"	3"	1"	1/8"
3/4"	2 1/4"	2 5/8"	2 5/8"	2 5/8"	2 3/4"	2 3/4"	3"	3"	1"	1/8"
1"	2 5/8"	2 7/8"	2 7/8"	2 7/8"	3 1/8"	3 1/8"	3 3/8"	4"	1"	1/8"
1 1/4"	3"	3 1/4"	3 1/4"	3 1/4"	3 1/2"	3 1/2"	4 1/8"	4"	1"	1/8"
1 1/2"	3 3/8"	3 3/4"	3 3/4"	3 3/4"	3 7/8"	3 7/8"	4 5/8"	4"	1"	1/8"
2"	4 1/8"	4 3/8"	4 3/8"	4 3/8"	5 5/8"	5 5/8"	5 3/4"	4"	1"	1/8"
2 1/2"	4 7/8"	5 1/8"	5 1/8"	5 1/8"	6 1/2"	6 1/2"	6 5/8"	4"	1"	1/8"
3"	5 3/8"	5 7/8"	5 7/8"	5 7/8"	6 5/8"	6 7/8"	7 3/4"	4"	1"	1/8"
4"	6 7/8"	7 1/8"	7"	7 5/8"	8 1/8"	8 1/4"	9 1/4"	4"	1"	1/8"
5"	7 3/4"	8 1/2"	8 3/8"	9 1/2"	9 3/4"	10"	11"	5"	1 1/2"	1/8"
6"	8 3/4"	9 7/8"	9 3/4"	10 1/2"	11 3/8"	11 1/8"	12 1/2"	5"	1 1/2"	1/8"
8"	11"	12 1/8"	12"	12 5/8"	14 1/8"	13 7/8"	15 1/4"	5"	1 1/2"	1/8"
10"	13 3/8"	14 1/4"	14 1/8"	15 3/4"	17 1/8"	17 1/8"	18 3/4"	5"	1 1/2"	1/4"
12"	16 1/8"	16 5/8"	16 1/2"	18"	19 5/8"	20 1/2"	21 5/8"	5"	1 1/2"	1/4"
14"	17 3/4"	19 1/8"	19"	19 3/8"	20 1/2"	22 3/4"	5"	1 1/2"	1/4"
16"	20 1/4"	21 1/4"	21 1/8"	22 1/4"	22 5/8"	25 1/4"	6"	1 1/2"	1/4"
18"	21 1/2"	23 3/8"	23 1/4"	24"	25"	27 5/8"	6"	1 1/2"	1/4"
20"	23 3/4"	25 5/8"	25 3/8"	26 3/4"	27 3/8"	29 5/8"	6"	1 1/2"	3/8"
22"	26"	27 3/4"	27 1/2"	28 7/8"	6"	1 1/2"	3/8"
24"	28 1/8"	30 3/8"	30 1/8"	31"	32 7/8"	35 1/2"	6"	1 1/2"	3/8"

When ordering please specify:

1. Size, Flange series
2. Material
3. Required bore size
4. Plate Thickness

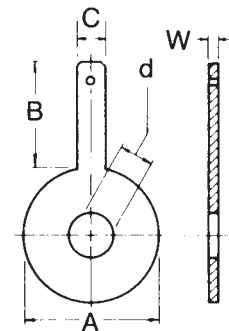

Diameters of holes in Paddle Plate Handles

Plate Size	Hole Diameter
1/2" thru 2"	1/4"
2 1/2" thru 12"	3/8"
14" thru 24"	1/2"
26" and larger	3/4"

ORIFICE PLATES (SERIES 500)

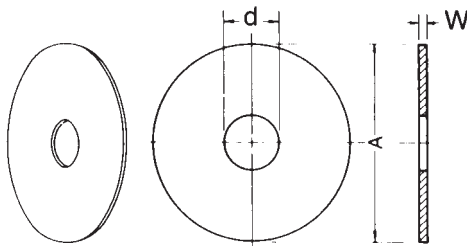

The Universal Series 500 Orifice Plate fits all orifice fittings and is interchangeable with other universal type plates.

MATERIALS:

Available in 304 and 316 Stainless Steel, Monel or Hastelloy "B" or "C" are available upon special request. All materials meet AGA or ASME specifications, and recommendations for inspection, manufacturing tolerance and finish. Bored to specification, or furnished blank if requested. d = Bore size. Dependant on engineer review, provided by the customer.

SIZE	A	W	WEIGHT
1	1.312	1/8	.05
1 1/2	2.000	1/8	.11
2	2.437	1/8	.17
2 1/2	2.812	1/8	.26
3	3.347	1/8	.34
4	4.406	1/8	.55
5	6.000	1/8	.95
6	6.437	1/8	1.18
8	8.437	1/4	2.03
10	10.687	1/4	3.25
12	12.593	1/4	4.51
14	14.000	1/4	5.58
16	16.000	3/8	7.29
18	18.000	3/8	18.45
20	20.000	3/8	22.78
24	24.000	3/8	32.80
26	26.000	3/8	38.50
30	30.000	1/2	51.25

d-BORE TO BE SPECIFIED

BLEED RINGS

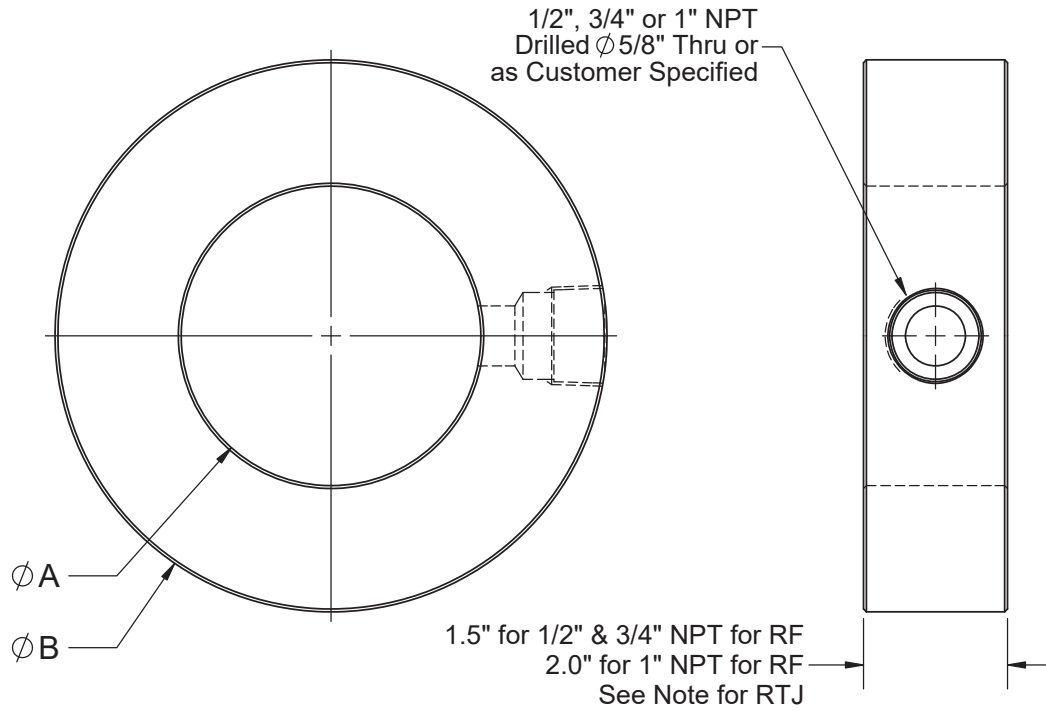

PIPE SIZE	DIMENSIONS IN INCHES											
	150		300		600		900		1500		2500	
	A	B	A	B	A	B	A	B	A	B	A	B
1	1	2.50	1	2.75	1	2.75	1	3.00	1.05	3.00	1.05	3.25
1 1/2	1.5	3.25	1.5	3.62	1.5	3.62	1.5	3.75	1.61	3.75	1.61	4.50
2	2.12	4.00	2.12	4.25	2.12	4.25	2.12	5.50	2.07	5.50	2.07	5.62
2 1/2	2.62	4.75	2.62	5.00	2.62	5.00	2.62	6.38	2.47	6.38	2.47	6.50
3	3.12	5.25	3.12	5.75	3.12	5.75	3.12	6.50	3.07	6.75	3.07	7.62
4	4.12	6.75	4.12	7.00	4.12	7.50	4.12	8.00	4.03	8.12	4.03	9.12
5	5.12	7.62	5.12	8.38	5.12	9.38	5.12	9.62	5.05	9.88	5.05	10.88
6	6.12	8.62	6.12	9.75	6.12	10.38	6.12	11.25	6.06	11.00	6.06	12.38
8	8.12	10.88	8.12	12.00	8.12	12.50	8.12	14.00	7.98	13.75	7.81	15.12
10	10.12	13.25	10.12	14.12	10.12	15.62	10.12	17.00	10.02	17.00	9.75	18.62
12	12.12	16.00	12.12	16.50	12.12	17.88	12.12	19.50	11.94	20.38	11.37	21.50
14	14.00	17.62	14.00	19.00	13.62	19.25	13.62	20.38	13.12	22.62	-	-
16	16.00	20.12	16.00	21.12	15.62	22.12	15.62	22.50	15.00	25.12	-	-
18	18.00	21.50	18.00	23.38	17.62	24.00	17.62	25.00	16.88	27.62	-	-
20	20.00	23.75	20.00	25.62	19.56	26.75	19.56	27.38	18.81	29.62	-	-
24	24.00	28.12	24.00	30.38	23.50	31.00	23.50	32.88	22.62	35.38	-	-

NOTE: FEMALE RING JOINT FACING AVAILABLE THICKNESS WILL BE AS PER ASME RTJ
 FIGURE 8 BLINDS PLUS THE FOLLOWING (1/2" NPT + 7/8") - (3/4" NPT + 1") - (1" NPT + 1-3/8")

Specialty Items

**VENTED BLINDS
ASSEMBLIES AVAILABLE**



FLAT STRAINERS

This style is primarily for applications where the flanges cannot be separated sufficiently to install a basket or conical strainer. Caution: The flow area of the pipe is generally reduced by at least fifty percent resulting in significant line losses and rapid clogging. Wire mesh overlay may be added for finer particle retention.

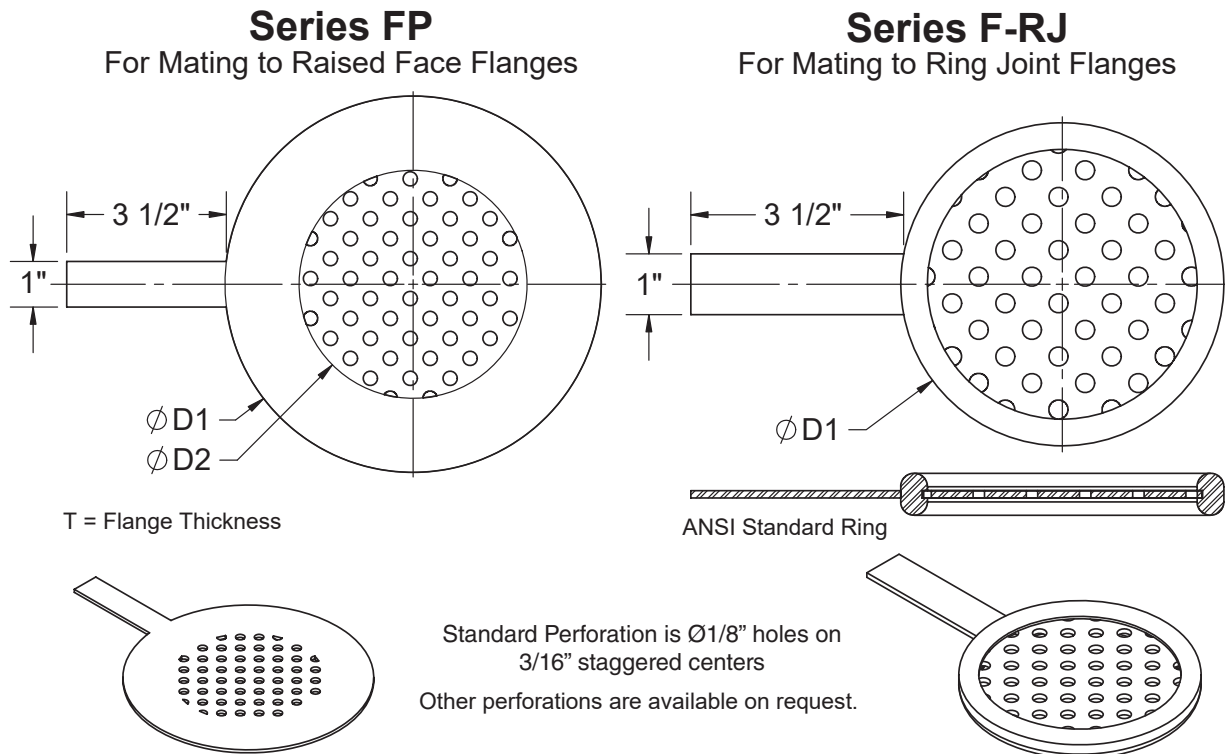

* Should D1 = Ring Size (R15)

RAISED FACE

STYLE	PIPE	150 lb.			300 lb.		
		D1	D2	T	D1	D2	T
FP	3/4	2 1/8	3/4	11ga	2 1/2	3/4	11ga
FP	1	2 1/2	1	11ga	2 3/4	1	11ga
FP	1 1/4	2 3/4	1 1/4	11ga	3	1 1/4	11ga
FP	1 1/2	3 1/8	1 1/2	11ga	3 1/2	1 1/2	11ga
FP	2	3 7/8	2	11ga	4 1/8	2	11ga
FP	2 1/2	4 5/8	2 1/2	11ga	4 7/8	2 1/2	11ga
FP	3	5 1/8	3	11ga	5 5/8	3	11ga
FP	3 1/2	6 1/8	3 1/2	11ga	6 1/8	3 1/2	11ga
FP	4	6 5/8	4	11ga	6 7/8	4	11ga
FP	5	7 1/2	5	11ga	8 1/4	5	11ga
FP	6	8 1/2	6	11ga	9 5/8	6	11ga
FP	8	10 3/4	8	11ga	11 7/8	8	11ga
FP	10	13 1/4	10	11ga	14	10	11ga
FP	12	15 7/8	12	11ga	16 3/8	12	11ga
FP	14	17 1/2	13 1/4	11ga	18 7/8	13 1/4	11ga
FP	16	20	15 1/4	11ga	21	15 1/4	11ga
FP	18	21 3/8	17	11ga	23 1/4	17	11ga
FP	20	23 5/8	19	11ga	25 1/2	19	11ga
FP	24	28	23	11ga	30 1/4	23	11ga
FP	30	34 1/4	29	3/16	37 1/8	29	3/16
FP	36	40 3/4	35	3/16	43 1/2	35	3/16

RING JOINT

STYLE	300 & 600 lb.		900 lb.	
	D1	T	D1	T
FRJ	1 3/8	11ga	1 7/16	11ga
FRJ	1 11/16	11ga	1 11/16	11ga
FRJ	2 1/16	11ga	2 1/16	11ga
FRJ	2 3/8	11ga	2 3/8	11ga
FRJ	2 13/16	11ga	3 5/16	11ga
FRJ	3 9/16	11ga	3 13/16	11ga
FRJ	4 7/16	11ga	4 7/16	11ga
FRJ	4 3/4	11ga	4 3/4	11ga
FRJ	5 7/16	11ga	5 7/16	11ga
FRJ	6 11/16	11ga	6 11/16	11ga
FRJ	7 7/8	11ga	7 7/8	11ga
FRJ	10 3/16	11ga	10 3/16	11ga
FRJ	12 5/16	11ga	12 5/16	11ga
FRJ	14 9/16	11ga	14 9/16	11ga
FRJ	16 1/16	11ga	15 7/8	11ga
FRJ	18 1/16	11ga	17 7/8	11ga
FRJ	20 9/16	11ga	20 1/4	11ga
FRJ	22 1/2	11ga	22 1/4	11ga
FRJ	26 5/8	11ga	26 1/4	11ga
FRJ	33	11ga	32 1/2	11ga
FRJ	39 3/8	11ga	38 7/8	11ga

PERFORATED CONE TYPE STRAINERS

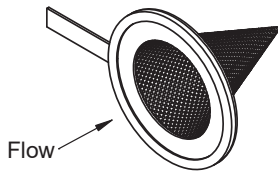
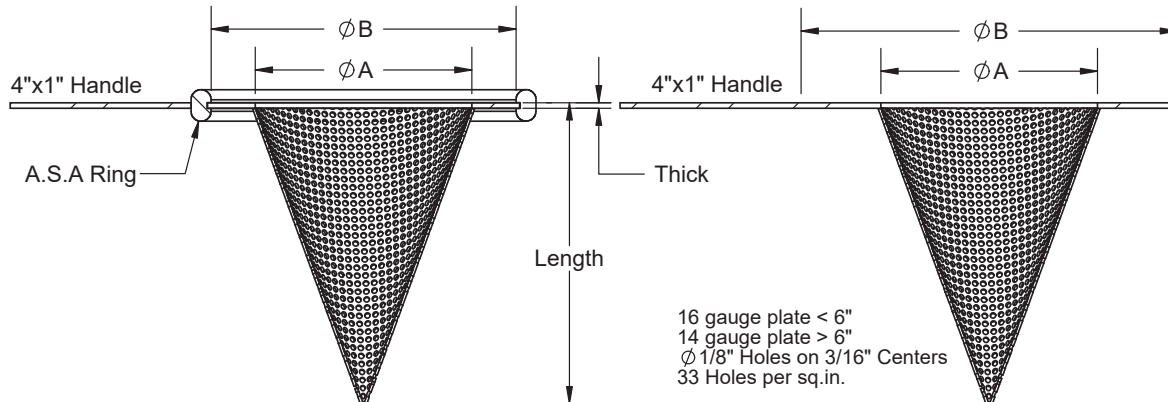

Wire cloth on inside perforated support

Wire Mesh is available Inside or Outside upon request. Please Specify Flow Direction.

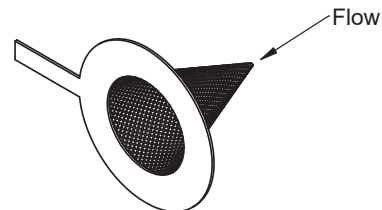

Wire cloth on outside perforated support

PIPE SIZE	"A" DIM.	RING NUMBER	"B" DIA.			RTJ 300 600	LENGTH			THICK		APPROX. WT. lbs
			RF & FF				100%	150%	200%	RF	RTJ	
			150	300	600							
3/4	5/8	R13	2 1/4	2 1/2	2 1/2	1 3/8	1 1/2	2 1/2	3	IIGA	IIGA	1/2
1	7/8	R16	2 1/2	2 1/2	2 1/2	1 11/16	2	2 1/2	3 1/2	"	"	1/2
1 1/4	1	R18	2 3/4	3	3	2 1/16	2 1/2	3 1/2	4 1/2	"	"	1/2
1 1/2	1 3/8	R20	3 1/4	3 1/2	3 1/2	2 3/8	2 1/2	3 1/2	5	"	"	1/2
2	1 3/4	R23	4	4 1/4	4 1/4	2 13/16	3	4 1/2	6	"	"	1/2
2 1/2	2 1/4	R26	4 3/4	5	5	3 9/16	3 1/2	5	7	"	"	1
3	2 3/4	R31	5 1/4	5 3/4	5 3/4	4 7/16	4	6	8 1/2	"	"	1
3 1/2	3 1/4	R34	6 1/4	6 1/4	6 1/4	4 3/4	4 1/2	7	9 1/2	"	"	1 1/2
4	3 3/4	R37	6 3/4	7	7 1/2	5 7/16	5 1/2	8	11	"	"	1 1/2
5	4 3/4	R41	7 1/2	8 1/4	9 1/4	6 11/16	6 1/2	10	13 1/2	"	"	2
6	5 5/8	R45	8 1/2	9 3/4	10 1/4	7 7/8	7 1/2	12	16	"	"	2 1/2
8	7 1/2	R49	10 3/4	12	12 1/2	10 3/16	10	15 1/2	21	"	"	3 1/2
10	9 3/8	R53	13 1/4	14	15 1/2	12 5/16	12 1/2	19 1/2	26 1/2	"	"	4 1/2
12	11 5/8	R57	16	16 1/2	17 3/4	14 9/16	15	23	31	"	"	6
14	12 7/8	R61	17 1/2	19	19 1/4	16 1/16	16	25 1/2	34	"	"	10
16	14 7/8	R65	20	21	22	18 1/16	18 1/2	29	39	"	"	20
18	16 7/8	R69	21 1/2	23 1/4	24	20 9/16	21	32 1/2	44	"	"	30
20	18 7/8	R73	23 3/4	25 1/2	26 3/4	22 1/2	23	36	49	"	"	40
24	22 7/8	R77	28	30 1/4	31	26 5/8	27 1/2	43 1/2	58 1/2	"	"	55
30	28 1/2	R95	34 1/4	37 1/4	37 3/4	33	35 1/2	55 1/2	74 1/2	"	"	70
36	34 1/2	R98	40 3/4	43 1/2	44	39 3/8	42	66	89 1/2	"	"	90

* Different pressure classes have different ring sizes.

BASKET TYPE STRAINERS

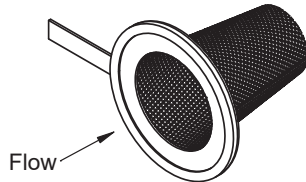
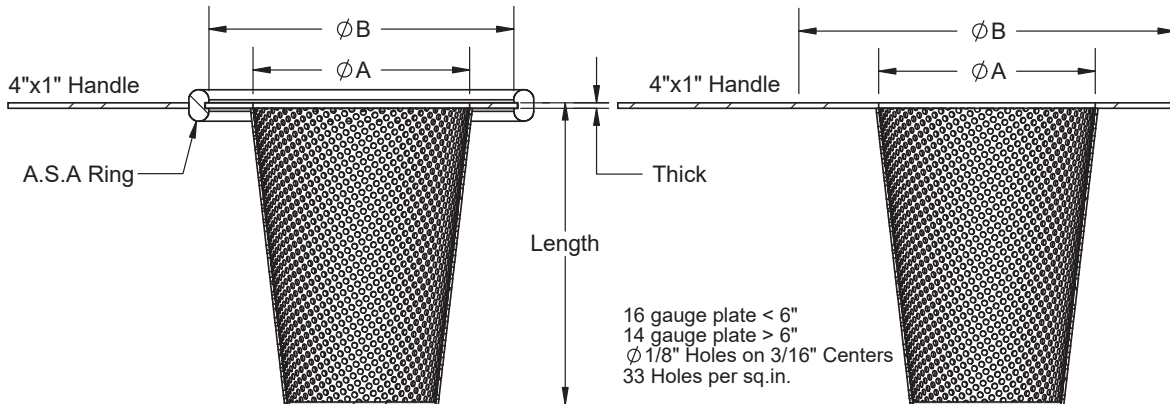

Wire cloth on inside perforated support

Wire Mesh is available Inside or Outside upon request. Please Specify Flow Direction.



Wire cloth on outside perforated support

PIPE SIZE	"A" DIM.	"C" DIM.	RING NUMBER	"B" DIA.				LENGTH (% OPEN AREA)			THICK		APPROX. WT. lbs
				RF & FF			RTJ 300 600	100%	150%	200%	RF	RTJ	
				150	300	600							
3/4	5/8	3/8	R13	2 1/4	2 1/2	2 1/2	1 3/8	1	1 1/2	1 1/2	IIGA	IIGA	1/2
1	7/8	1/2	R16	2 1/2	2 1/2	2 1/2	1 11/16	1	1 1/2	2	"	"	1/2
1 1/4	1	3/4	R18	2 3/4	3	3	2 1/16	1	2	2 1/2	"	"	1/2
1 1/2	1 3/8	3/4	R20	3 1/4	3 1/2	3 1/2	2 3/8	1 1/2	2	3	"	"	1/2
2	1 3/4	1 1/4	R23	4	4 1/4	4 1/4	2 13/16	1 1/2	2 1/2	3 1/2	"	"	1/2
2 1/2	2 1/4	1 1/2	R26	4 3/4	5	5	3 9/16	2	3 1/2	4 1/2	"	"	1/2
3	2 3/4	2	R31	5 1/4	5 3/4	5 3/4	4 7/16	3	4 1/2	5 1/2	"	"	1/2
3 1/2	3 1/4	2 1/4	R34	6 1/4	6 1/4	6 1/4	4 3/4	3	4 1/2	5 1/2	"	"	1
4	3 3/4	2 1/2	R37	6 3/4	7	7 1/2	5 7/16	3	4 1/2	6	"	IIGA	1
5	4 3/4	3 1/4	R41	7 1/2	8 1/4	9 1/4	6 11/16	3 1/2	5 1/2	7 1/2	"	"	1 1/2
6	5 5/8	4	R45	8 1/2	9 3/4	10 1/4	7 7/8	4	6 1/2	9	"	"	2
8	7 1/2	5 1/2	R49	10 3/4	12	12 1/2	10 3/16	5	8	11	"	"	4
10	9 3/8	7 1/4	R53	13 1/4	14	15 1/2	12 5/16	6	10	14	"	"	6
12	11 5/8	8 3/4	R57	16	16 1/2	17 3/4	14 9/16	7 1/2	12	16 1/2	"	"	8
14	12 7/8	10	R61	17 1/2	19	19 1/4	16 1/16	7 1/2	12 1/2	17 1/2	IIGA	"	10
16	14 7/8	11 3/4	R65	20	21	22	18 1/16	9	14 1/2	20 1/2	"	"	12
18	16 7/8	13 1/2	R69	21 1/2	23 1/4	24	20 9/16	10 1/2	17	23 1/2	"	"	16
20	18 7/8	15	R73	23 3/4	25 1/2	26 3/4	22 1/2	11	18 1/2	25 1/2	"	"	20
24	22 7/8	18	R77	28	30 1/4	31	26 5/8	13 1/2	22 1/2	31	"	"	30
30	28 1/2	20	R95	34 1/4	37 1/4	37 3/4	33	15 1/2	26	36 1/2	"	"	40
36	34 1/2	26	R98	40 3/4	43 1/2	44	39 3/8	18 1/2	31	43 1/2	"	"	50

* Different pressure classes have different ring sizes.

TEE TYPE STRAINERS

PIPE SIZE	DIMENSIONS IN INCHES					
	150 # RATING			300 # RATING		
	A	B	C	A	B	C
2	5	10	5	5	10 1/2	5 1/4
2 1/2	6	11 1/2	5 3/4	6	12	6
3	6 3/4	12 1/4	6 1/8	6 3/4	13	6 1/2
4	8 1/4	14 1/4	7 1/8	8 1/4	15	7 1/2
5	9 3/4	16 3/4	8 3/8	9 3/4	17 1/2	8 3/4
6	11 1/4	18 1/4	9 1/8	11 1/4	19	9 1/2
8	14	22	11	14	22 3/4	11 3/8
10	17	25	12 1/2	17	26 1/4	13 1/8
12	20	29	14 1/2	20	30 1/4	15 1/8
14	22	32	16	22	33 1/4	16 5/8
16	24	34	17	24	35 1/2	17 3/4
18	27	38	19	27	39 1/2	19 3/4
20	30	41 3/8	20 11/16	30	42 3/4	21 3/8
24	34	46	23	34	47 1/4	23 5/8

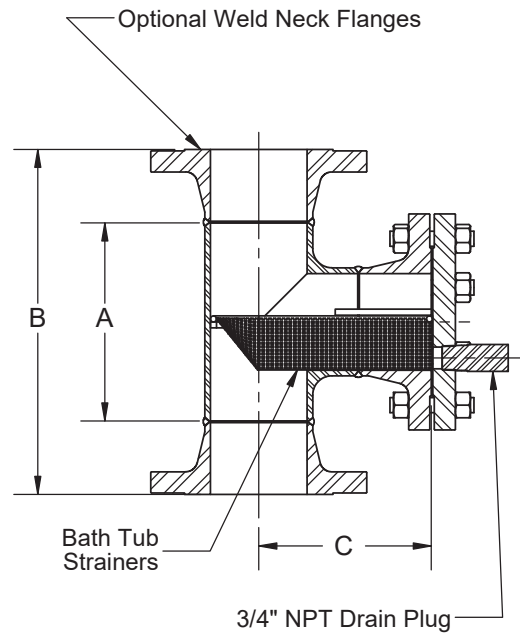

BATH TUB TYPE STRAINERS

PIPE SIZE	SCH.	DIMENSIONS IN INCHES					
		150 # RATING			300 # RATING		
		A	B	C	A	B	C
2	40	1 15/16	1 1/4	6	1 15/16	1 1/4	6 1/4
	80	1 13/16	1 3/16	5 15/16	1 13/16	1 3/16	6 3/16
	160	1 9/16	1 1/16	5 13/16	1 9/16	1 1/16	6 1/16
2 1/2	40	2 5/16	1 7/16	6 15/16	2 5/16	1 7/16	7 3/16
	80	2 3/16	1 3/8	6 7/8	2 3/16	1 3/8	7 1/8
	160	2	1 5/16	6 13/16	2	1 5/16	7 1/16
3	40	2 15/16	1 3/4	7 5/8	2 15/16	1 3/4	8
	80	2 3/4	1 11/16	7 9/16	2 3/4	1 11/16	7 15/16
	160	2 1/2	1 9/16	7 7/16	2 1/2	1 9/16	7 15/16
4	40	3 7/8	2 1/4	9 1/8	3 7/8	2 1/4	9 1/2
	80	3 11/16	2 1/8	9	3 11/16	2 1/8	9 3/8
	160	3 5/16	1 15/16	8 13/16	3 5/16	1 15/16	9 3/16
6	40	5 15/16	3 3/8	12 1/8	5 15/16	3 3/8	12 1/2
	80	5 5/8	3 1/4	12	5 5/8	3 1/4	12 3/8
	160	5 5/16	2 15/16	11 11/16	5 1/16	2 15/16	12 1/16
8	40	7 13/16	4 5/16	15	7 13/16	4 5/16	15 5/16
	80	7 1/2	4 3/16	14 13/16	7 1/2	4 3/16	15 3/16
	160	6 11/16	3 3/4	14 3/8	6 11/16	3 3/4	14 3/4
10	40	9 7/8	5 3/8	17 1/2	9 7/8	5 3/8	18 1/8
	80	9 7/16	8 1/8	17 1/4	9 7/16	5 1/8	17 7/8
	160	8 3/8	4 5/8	16 3/4	8 3/8	4 5/8	17 3/8
12	40	11 7/8	6 3/8	20 1/2	11 7/8	6 3/8	21 1/8
	80	11 5/8	6 1/16	20 3/16	11 5/8	6 1/4	21
	160	10	5 7/16	19 9/16	10	5 7/16	20 3/16

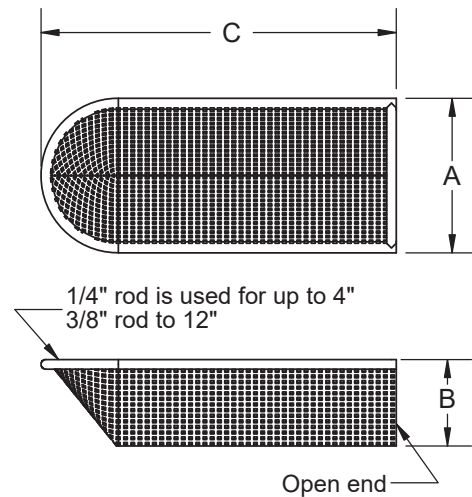

PERMANENT STRAINERS

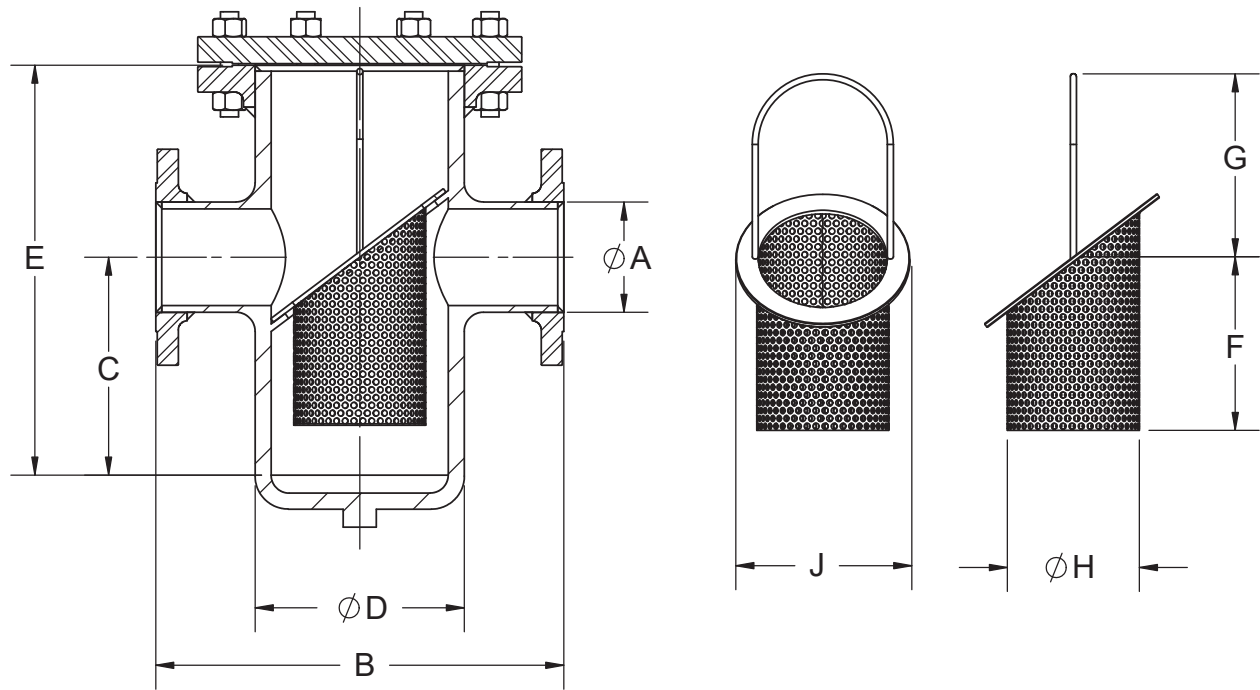

DIMENSIONS IN INCHES

PIPE SIZE	150									300								
	A	B	C	D	E	F	G	H	J	A	B	C	D	E	F	G	H	J
2	2 3/8	15	7	4 1/2	15	5	8 1/8	2 1/4	3 1/2	2 3/8	17	7	4 1/2	15 1/2	5	8 5/8	2 1/4	3 1/2
3	3 1/2	18	7	6 5/8	15	5	8 1/8	3 3/4	5 1/2	3 1/2	20	7	6 5/8	15 1/2	5	8 5/8	3 3/4	5 1/2
4	4 1/2	22	9	8 5/8	17	7	8 1/8	5 1/2	7 1/4	4 1/2	24	9	8 5/8	17 1/2	7	8 5/8	5 1/2	7 1/4
6	6 5/8	24	12	10 3/4	22	10	10 1/8	7 1/2	9 1/4	6 5/8	27	12	10 3/4	22 3/4	10	10 7/8	7 1/2	9 1/4
8	8 5/8	28	13	12 3/4	24	11	11 1/8	9 1/4	11 1/4	8 5/8	31	13	12 3/4	24 3/4	11	11 7/8	9 1/4	11 1/4
10	10 3/4	34	14	16	26	12	12 1/8	12 1/4	14 1/2	10 3/4	37	14	16	26 3/4	12	12 7/8	12 1/4	14 1/2
12	12 3/4	36	16	18	29	13 1/2	13 1/8	13	16 1/2	12 3/4	40	16	18	29 3/4	13 1/2	13 7/8	13	16 1/2
14	14	39	17	20	31	14 1/2	14 1/8	15 1/4	18 1/2	14	43	17	20	31 3/4	14 1/2	14 7/8	15 1/4	18 1/2
16	16	44	19	24	34	16	15 1/8	18 1/4	22 1/2	16	49	19	24	34 3/4	16	15 7/8	18 1/4	22 1/2
18	18	44	19	24	34	16	15 1/8	18 1/4	22 1/2	18	49	19	24	34 3/4	16	15 7/8	18 1/4	22 1/2
20	20	44	21	24	38	18	17 1/8	18 1/4	22 1/2	20	49	21	24	38 3/4	18	17 7/8	18 1/4	22 1/2
24	24	49	22	30	40	19	18 1/8	22	28	24	50	22	30	41	19	19 1/8	22	28
30	30	59	26	36	48	23	22 1/8	30 1/4	34 1/4	30	60	26	36	49	23	23 1/8	30 1/4	34 1/4
36	36	69	30	42	56	26	26 1/8	35 1/2	39 3/4	36	69	30	42	57	26	27 1/8	35 1/2	39 3/4
42	42	72	34	48	62	30	28 1/8	41 1/2	45 3/4	42	72	34	48	63	30	29 1/8	41 1/2	45 3/4

API FLANGES

SECTION 4a API 6A TYPE 6B, 6BX Flanges and Studded Crosses and Tees

Flanges and Studded Blocks are designed and manufactured in accordance with the following specifications:

API 6A	Specification for Wellhead and Christmas Tree Equipment.
ANSI B31.3	Chemical Plant and Petroleum Refinery Piping.
ASME VIII	Boiler and Pressure Vessel Code.
MSS-SP-55	Quality Standards for Steel Castings for Valves, Flanges and Fittings and other Piping Components.
NACE MR-01-75	Sulphide Stress Cracking Resistant Metallic Materials for Oilfield Equipment.

Flanges are available as Weld Neck, Integral, Blinds, Target & Test Blinds for use with the following pressure ratings:

MAX. WORKING PRESSURE	2,000 PSI	3000 PSI	5,000 PSI	10,000 PSI	2000 PSI	2000 PSI
TEST PRESSURE	3,000 PSI	4,500 PSI	7,500 PSI	15,000 PSI	22,000 PSI	30,000 PSI
PRODUCT SPECIFICATION LEVELS	1,2,3	1,2,3	1,2,3	1,2,3	1,2,3	1,2,3
API TEMPERATURE RATING	K (-60 DEG C) TO Y (+345 DEG C)	K (-60 DEG C) TO Y (+345 DEG C)	K (-60 DEG C) TO Y (+345 DEG C)	K (-60 DEG C) TO Y (+345 DEG C)	K (-60 DEG C) TO Y (+345 DEG C)	K (-60 DEG C) TO Y (+345 DEG C)
INTEGRAL, BLIND, TARGET BLIND & TEST FLANGES AND STUDED BLOCKS						
MIN. YIELD	60,000 PSI	60,000 PSI	60,000 PSI	60,000 PSI	75,000 PSI	75,000 PSI
MIN. TENSILE	85,000 PSI	85,000 PSI	85,000 PSI	85,000 PSI	95,000 PSI	95,000 PSI
MATERIAL	API 60K	API 60K	API 60K	API 60K	API 75K	API 75K
WELD NECK FLANGES						
MIN. YIELD	45,000 PSI	45,000 PSI	45,000 PSI	60,000 PSI	75,000 PSI	75,000 PSI
MIN. TENSILE	70,000 PSI	70,000 PSI	70,000 PSI	85,000 PSI	95,000 PSI	95,000 PSI
MATERIAL	API 45K	API 45K	API 45K	API 60K	API 75K	API 75K

GENERAL NOTES: Max. working pressures stated are suitable for temperatures up to 121°C.
De-rating of max. working pressure will occur as the operating temperature increases above 121°C.

TYPE 6B FLANGES FOR 2000 psi RATED WORKING PRESSURE

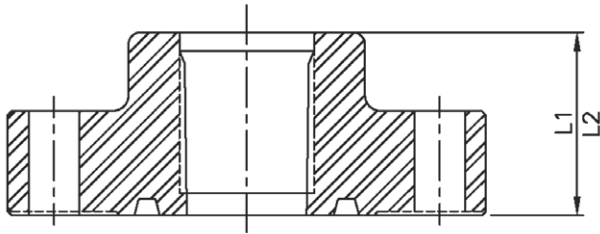

THREADED FLANGE

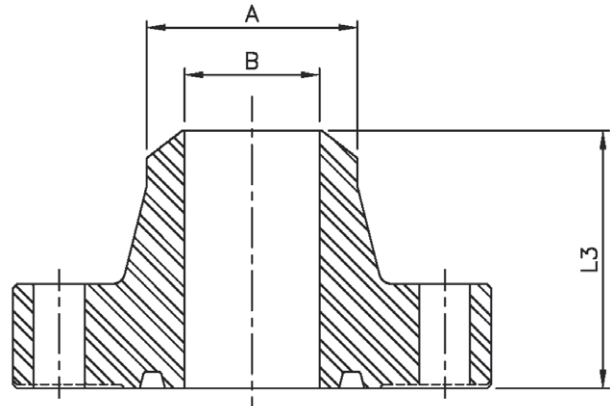

WELD NECK LINE PIPE FLANGE

HUB AND BORE DIMENSIONS

Nominal Size and Bore of Flange	Hub Length Threaded Line-Pipe Flange	Hub Length Threaded Casing Flange	Hub Length Welding Neck Line-Pipe Flange	Neck Diameter Welding Neck Line-Pipe Flange	Tolerance	Maximum Bore of Welding Neck Flange
	L1	L2	L3±0.06	A	A	B
2 ¹ / ₁₆	1.75	—	3.19	2.38	+0.09/-0.03	2.10
2 ⁹ / ₁₆	1.94	—	3.44	2.88	+0.09/-0.03	2.50
3 ¹ / ₈	2.12	—	3.56	3.50	+0.09/-0.03	3.10
4 ¹ / ₁₆	2.44	3.50	4.31	4.50	+0.09/-0.03	4.06
5 ¹ / ₈	2.69	4.00	4.81	5.56	+0.09/-0.08	4.84
7 ¹ / ₁₆	2.94	4.50	4.94	6.63	+0.16/-0.03	5.79
9	3.31	5.00	5.56	8.63	+0.16/-0.03	7.84
11	3.69	5.25	6.31	10.75	+0.16/-0.03	9.78
13 ⁵ / ₈	3.94	3.94	—	—	—	—
16 ³ / ₄	4.50	4.50	—	—	—	—
21 ¹ / ₄	5.38	5.38	—	—	—	—

GENERAL NOTES: Dimensions are in inches

TYPE 6B FLANGES FOR 2000 psi RATED WORKING PRESSURE

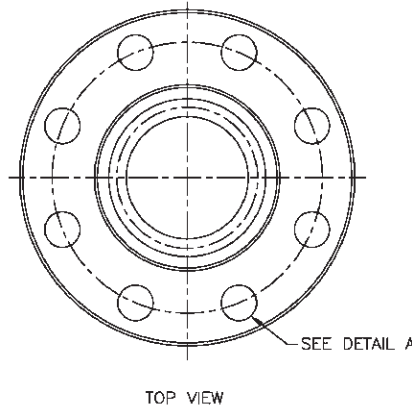
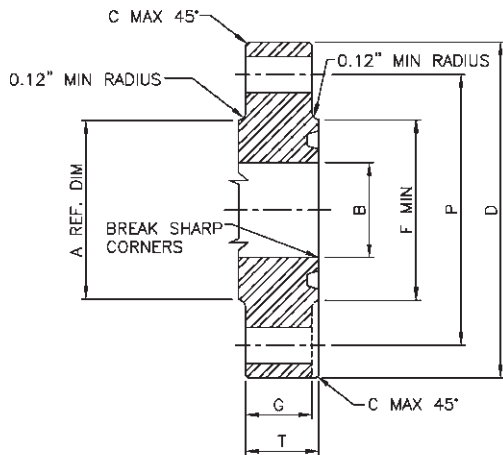

RING GROOVE MUST BE CONCENTRIC WITH BORE WITHIN 0.010 TOTAL INDICATOR RUNOUT

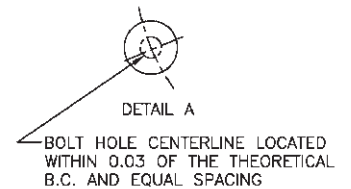

HUB AND BORE DIMENSIONS

Nominal Size and Bore of Flange	Maximum Bore	Outside Diameter of Flange	Tolerance	Maximum Chamfer	Diameter of Raised Face	Total Thickness of Flange	Basic Thickness of Flange	Diameter of Hub	Diameter of Bolt Circle	Number of Bolts	Diameter of Bolts	Diameter of Bolt Holes	Bolt Hole Tolerance (see note)	Length of Bolts	Ring Number, R or RX
	B	D	D	C	F	T	G	A	P						
2 ¹ / ₁₆	2.09	6.50	±0.06	0.12	4.25	1.31	1.00	3.31	5.00	8	5/8	0.75	+0.06	4.50	23
2 ¹ / ₈	2.59	7.50	±0.06	0.12	5.00	1.44	1.12	3.94	5.88	8	3/4	0.88	+0.06	5.00	26
3 ¹ / ₈	3.22	8.25	±0.06	0.12	5.75	1.56	1.25	4.62	6.62	8	3/4	0.88	+0.06	5.25	31
4 ¹ / ₁₆	4.28	10.75	±0.06	0.12	6.88	1.81	1.50	6.00	8.50	8	7/8	1.00	+0.06	6.00	37
5 ¹ / ₈	5.16	13.00	±0.06	0.12	8.25	2.06	1.75	7.44	10.50	8	1	1.12	+0.06	6.75	41
7 ¹ / ₁₆	7.16	14.00	±0.12	0.25	9.50	2.19	1.88	8.75	11.50	12	1	1.12	+0.06	7.00	45
9	9.03	16.50	±0.12	0.25	11.88	2.50	2.19	10.75	13.75	12	1 ¹ / ₈	1.25	+0.06	8.00	49
11	11.03	20.00	±0.12	0.25	14.00	2.81	2.50	13.50	17.00	16	1 ¹ / ₄	1.38	+0.06	8.75	53
13 ³ / ₈	13.66	22.00	±0.12	0.25	16.25	2.94	2.62	15.75	19.25	20	1 ¹ / ₄	1.38	+0.06	9.00	57
16 ³ / ₄	16.78	27.00	±0.12	0.25	20.00	3.31	3.00	19.50	23.75	20	1 ¹ / ₂	1.62	+0.09	10.25	65
21 ¹ / ₄	21.28	32.00	±0.12	0.25	25.00	3.88	3.50	24.00	28.50	24	1 ³ / ₈	1.75	+0.09	11.75	73

GENERAL NOTES: Dimensions are in inches. Minimum Bolt Hole Tolerance is - 0.02"

TYPE 6B FLANGES FOR 3000 psi RATED WORKING PRESSURE

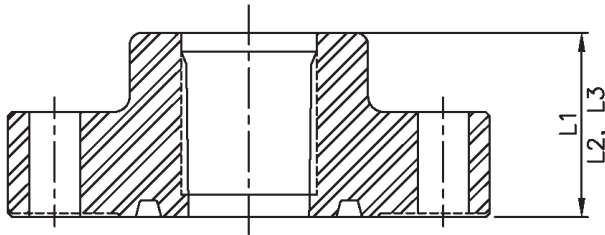

THREADED FLANGE

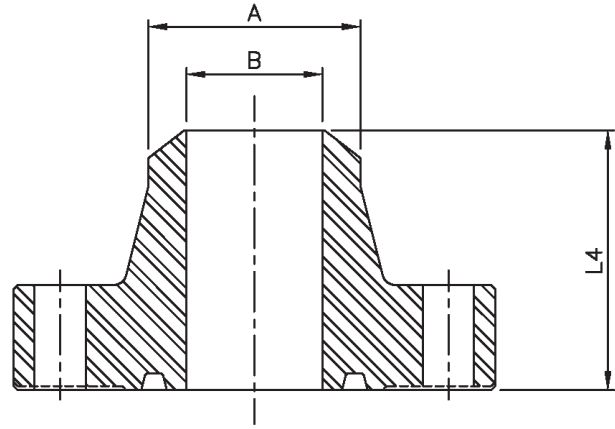

WELD NECK LINE PIPE FLANGE

HUB AND BORE DIMENSIONS

Nominal Size and Bore of Flange	Hub Length Threaded Line-Pipe Flange	Hub Length Threaded Casing Flange	Hub Length Tubing Flange	Hub Length Welding Neck Line-Pipe Flange	Neck Diameter Welding Neck Line-Pipe Flange	Tolerance	Maximum Bore of Welding Neck Flange
	L1	L2	L3	L4±0.06	A	A	B
2½	2.56	—	2.56	4.31	2.38	+0.09/-0.03	1.97
2¾	2.81	—	2.81	4.44	2.88	+0.09/-0.03	2.35
3⅛	2.44	—	2.94	4.31	3.50	+0.09/-0.03	2.93
4¼	3.06	3.50	3.50	4.81	4.50	+0.09/-0.03	3.86
5⅝	3.44	4.00	—	5.31	5.56	+0.09/-0.03	4.84
7¼	3.69	4.50	—	5.81	6.63	+0.016/-0.03	5.79
9	4.31	5.00	—	6.69	8.63	+0.016/-0.03	7.47
11	4.56	5.25	—	7.56	10.75	+0.016/-0.03	9.34
13⅝	4.94	4.94	—	—	—	—	—
16¾	5.06	5.69	—	—	—	—	—
20¾	6.75	6.75	—	—	—	—	—

GENERAL NOTES: Dimensions are in inches

TYPE 6B FLANGES FOR 3000 psi RATED WORKING PRESSURE

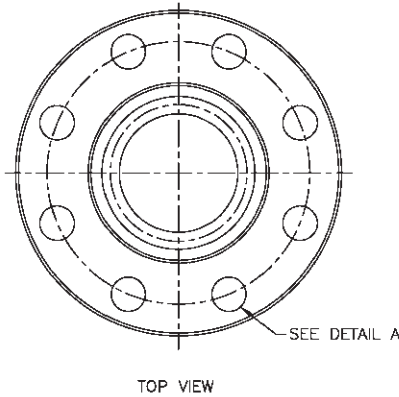
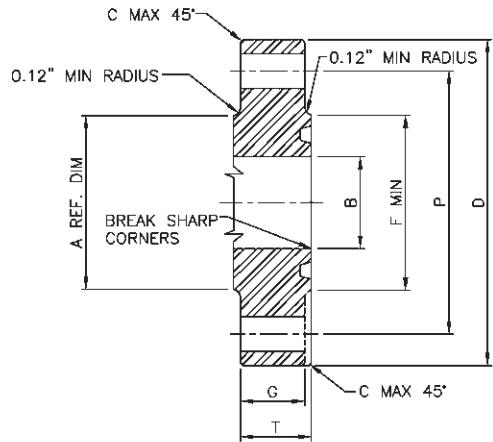

RING GROOVE MUST BE CONCENTRIC WITH BORE WITHIN 0.010 TOTAL INDICATOR RUNOUT

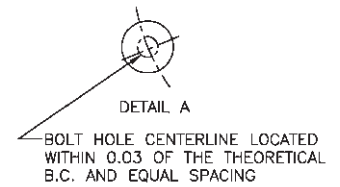

HUB AND BORE DIMENSIONS

Nominal Size and Bore of Flange	Maximum Bore	Outside Diameter of Flange	Tolerance	Maximum Chamfer	Diameter of Raised Face	Total Thickness of Flange	Basic Thickness of Flange	Diameter of Hub	Diameter of Bolt Circle	Number of Bolts	Diameter of Bolts	Diameter of Bolt Holes	Bolt Hole Tolerance (see note)	Length of Bolts	Ring Number, R or RX
	B	D	D	C	F	T	G	A	P						
2 ¹ / ₁₆	2.09	8.50	±0.06	0.12	4.88	1.81	1.50	4.12	6.50	8	7/8	1.00	+06	6.00	24
2 ³ / ₁₆	2.59	9.62	±0.06	0.12	5.38	1.94	1.62	4.88	7.50	8	1	1.12	+06	6.50	27
3 ¹ / ₁₆	3.22	9.50	±0.06	0.12	6.12	1.81	1.50	5.00	7.50	8	7/8	1.00	+06	6.00	31
4 ¹ / ₁₆	4.28	11.50	±0.06	0.12	7.12	2.06	1.75	6.25	9.25	8	11/8	1.25	+06	7.00	37
5 ¹ / ₁₆	5.16	13.75	±0.06	0.12	8.50	2.31	2.00	7.50	11.00	8	1 ¹ / ₄	1.38	+06	7.75	41
7 ¹ / ₁₆	7.16	15.00	±0.12	0.25	9.50	2.50	2.19	9.25	12.50	12	11/8	1.25	+06	8.00	45
9	9.03	18.50	±0.12	0.25	12.12	2.81	2.50	11.75	15.50	12	13/8	1.50	+06	9.00	49
11	11.03	21.50	±0.12	0.25	14.25	3.06	2.75	14.50	18.50	16	13/8	1.50	+06	9.50	53
13 ³ / ₁₆	13.66	24.00	±0.12	0.25	16.50	3.44	3.12	16.50	21.00	20	13/8	1.50	+06	10.25	57
16 ³ / ₁₆	16.78	27.75	±0.12	0.25	20.62	3.94	3.50	20.00	24.25	20	15/8	1.75	+09	11.75	66
20 ³ / ₁₆	20.78	33.75	±0.12	0.25	25.50	4.75	4.25	24.50	29.50	20	2	2.12	+09	14.50	74

GENERAL NOTES: Dimensions are in inches. Minimum Bolt Hole Tolerance is - 0.02"

TYPE 6B FLANGES FOR 5000 psi RATED WORKING PRESSURE

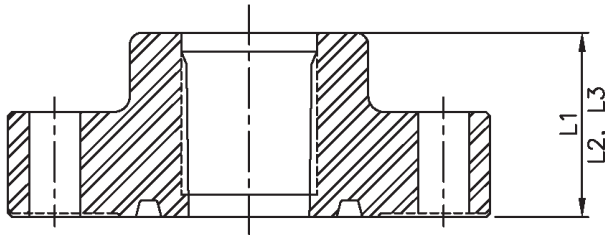

THREADED FLANGE

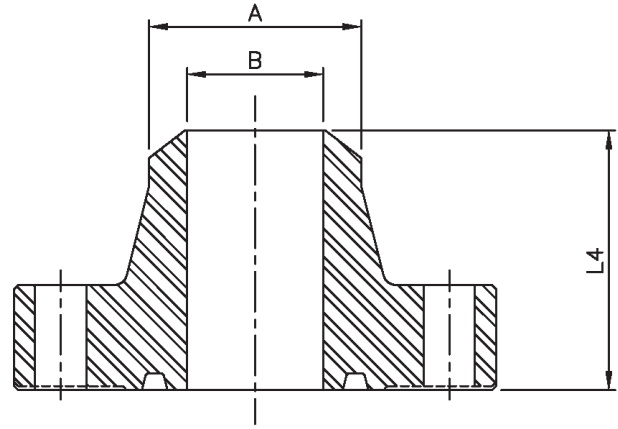

WELD NECK LINE PIPE FLANGE

HUB AND BORE DIMENSIONS

Nominal Size and Bore of Flange	Hub Length Threaded Line-Pipe Flange	Hub Length Threaded Casing Flange	Hub Length Tubing Flange	Hub Length Welding Neck Line-Pipe Flange	Neck Diameter Welding Neck Line-Pipe Flange	Tolerance	Maximum Bore of Welding Neck Flange
	L1	L2	L3	L4±0.06	A	A	B
2½ ₁₆	2.56	—	2.56	4.31	2.38	+0.09/-0.03	1.72
2 ⁹ / ₁₆	2.81	—	2.81	4.44	2.88	+0.09/-0.03	2.16
3 ¹ / ₈	3.19	—	3.19	4.94	3.50	+0.09/-0.03	2.65
4 ¹ / ₁₆	3.88	3.88	3.88	5.19	4.50	+0.09/-0.03	3.47
5 ¹ / ₈	4.44	4.44	—	6.44	5.56	+0.09/-0.03	4.34
7 ¹ / ₁₆	5.06	5.06	—	7.13	6.63	+0.016/-0.03	5.22
9	6.06	6.06	—	8.81	8.63	+0.016/-0.03	6.84
11	6.69	6.69	—	10.44	10.75	+0.016/-0.03	8.53

GENERAL NOTES: Dimensions are in inches

TYPE 6B FLANGES FOR 5000 psi RATED WORKING PRESSURE

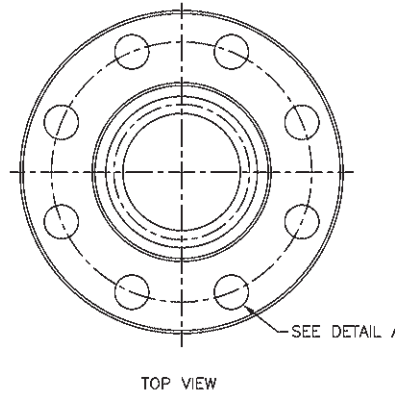
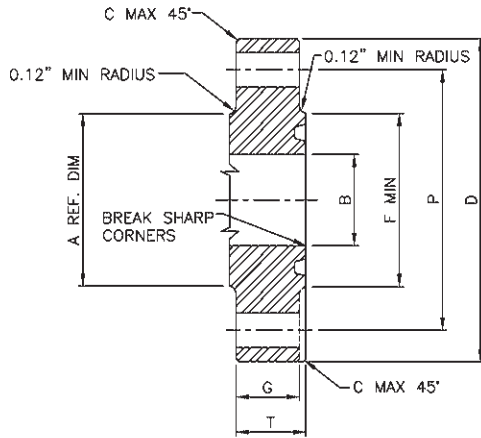

RING GROOVE MUST BE CONCENTRIC WITH BORE WITHIN 0.010 TOTAL INDICATOR RUNOUT

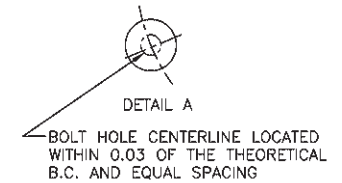

HUB AND BORE DIMENSIONS

Nominal Size and Bore of Flange	Maximum Bore	Outside Diameter of Flange	Tolerance	Maximum Chamfer	Diameter of Raised Face	Total Thickness of Flange	Basic Thickness of Flange	Diameter of Hub	Diameter of Bolt Circle	Number of Bolts	Diameter of Bolts	Diameter of Bolt Holes	Bolt Hole Tolerance (see note)	Length of Bolts	Ring Number, R or RX
	B	D	D	C	F	T	G	A	P						
2 $\frac{1}{16}$	2.09	8.50	±0.06	0.12	4.88	1.81	1.50	4.12	6.50	8	$\frac{7}{8}$	1.00	+06	6.00	24
2 $\frac{3}{16}$	2.59	9.62	±0.06	0.12	5.38	1.94	1.62	4.88	7.50	8	1	1.12	+06	6.50	27
3 $\frac{1}{8}$	3.22	10.50	±0.06	0.12	6.62	2.19	1.88	5.25	8.00	8	1 $\frac{1}{8}$	1.25	+06	7.25	35
4 $\frac{1}{16}$	4.28	12.25	±0.06	0.12	7.62	2.44	2.12	6.38	9.50	8	1 $\frac{1}{4}$	1.38	+06	8.00	39
5 $\frac{1}{8}$	5.16	14.75	±0.06	0.12	9.00	3.19	2.88	7.75	11.50	8	1 $\frac{1}{2}$	1.62	+06	10.00	44
7 $\frac{1}{16}$	7.16	15.50	±0.12	0.25	9.75	3.62	3.25	9.00	12.50	12	1 $\frac{3}{8}$	1.50	+06	10.75	46
9	9.03	19.00	±0.12	0.25	12.50	4.06	3.62	11.50	15.50	12	1 $\frac{5}{8}$	1.75	+09	12.00	50
11	11.03	23.00	±0.12	0.25	14.63	4.69	4.25	14.50	19.00	12	1 $\frac{7}{8}$	2.00	+09	13.75	54

GENERAL NOTES: Dimensions are in inches. Minimum Bolt Hole Tolerance is - 0.02"

TYPE 6BX INTEGRAL FLANGES FOR 2000, 3000, and 5000 psi RATED WORKING PRESSURE

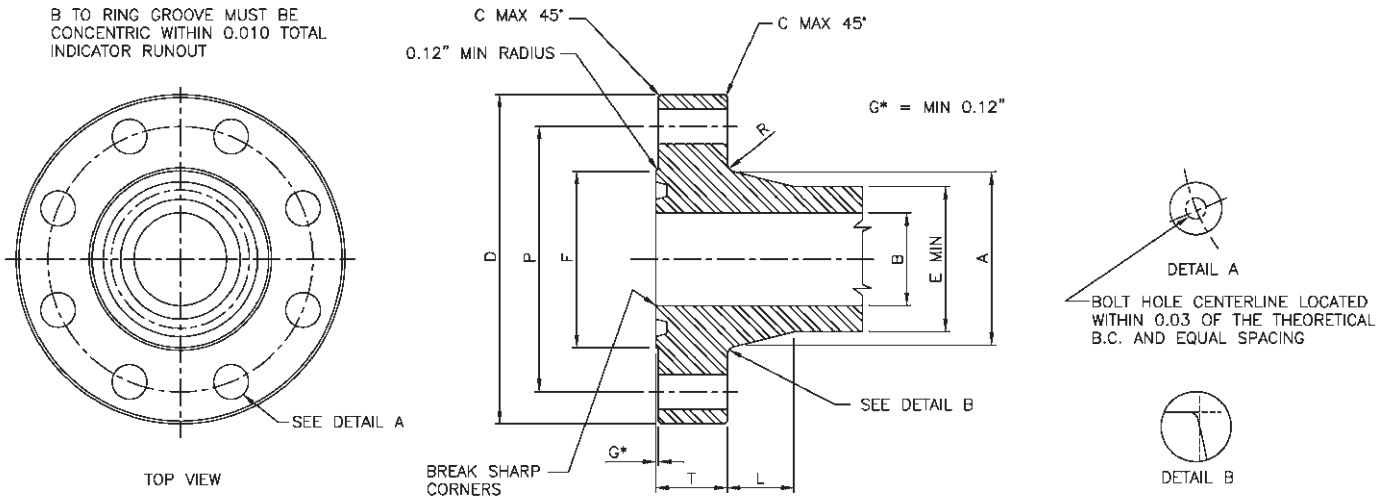

HUB AND FLANGE DIMENSIONS

Nominal Size and Bore of Flange	Maximum Bore	Outside Diameter of Flange	Tolerance	Maximum Chamfer	Diameter of Raised Face	Total Thickness of Flange	Large Diameter of Hub	Small Diameter of Hub	Length of Hub	Radius of Hub	Diameter of Bolt Circle	Number of Bolts	Diameter of Bolts	Diameter of Bolt Holes	Bolt Hole Tolerance (see note)	Minimum Length of Stud Bolts	Ring Number
B	D	D	C	F	T	A	E	L	R	P							BX
2000 psi																	
26 $\frac{3}{4}$	26.78	41.00	±0.12	0.25	31.69	4.97	32.91	29.25	7.31	0.62	37.50	20	1 $\frac{3}{4}$	1.88	+0.09	13.75	167
30	30.03	44.19	±0.12	0.25	35.75	5.28	36.69	32.80	7.75	0.62	40.94	32	1 $\frac{1}{2}$	1.75	+0.09	14.25	303
3000 psi																	
26 $\frac{3}{4}$	26.78	43.38	±0.12	0.25	32.75	6.34	34.25	30.56	7.31	0.62	39.38	24	2	2.12	+0.09	17.00	168
30	30.03	46.68	±0.12	0.25	36.31	6.58	38.19	34.30	7.75	0.62	42.94	32	1 $\frac{1}{2}$	2.00	+0.09	17.75	303
5000 psi																	
13 $\frac{3}{4}$	13.66	26.50	±0.12	0.25	18.00	4.44	18.94	16.69	4.50	0.62	23.25	16	1 $\frac{1}{2}$	1.75	+0.09	12.50	160
16 $\frac{3}{4}$	16.78	30.38	±0.12	0.25	21.06	5.13	21.88	20.75	3.00	0.75	26.62	16	1 $\frac{1}{2}$	2.00	+0.09	14.50	162
18 $\frac{3}{4}$	18.78	35.62	±0.12	0.25	24.69	6.53	26.56	23.56	6.00	0.62	31.62	20	2	2.12	+0.09	17.50	163
21 $\frac{1}{4}$	21.28	39.00	±0.12	0.25	27.62	7.12	29.88	26.75	6.50	0.69	34.88	24	2	2.12	+0.09	18.75	165

GENERAL NOTES: Dimensions are in inches. Minimum Bolt Hole Tolerance is -0.02

TYPE 6BX INTEGRAL FLANGES FOR 10 000 psi RATED WORKING PRESSURE

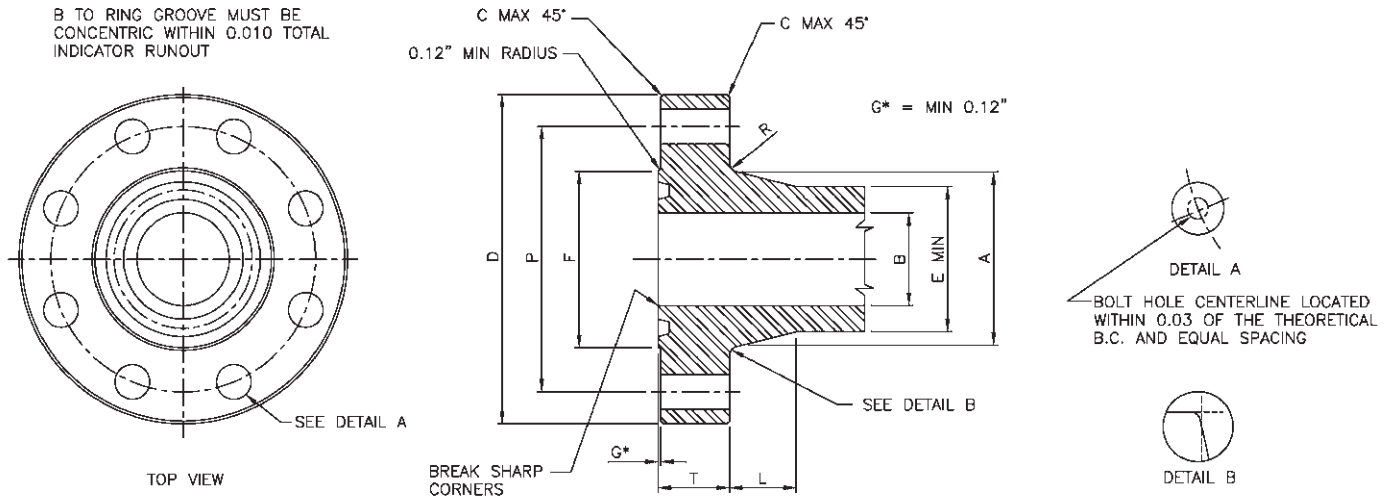

HUB AND FLANGE DIMENSIONS

Nominal Size and Bore of Flange	Maximum Bore	Outside Diameter of Flange	Tolerance	Maximum Chamfer	Diameter of Raised Face	Total Thickness of Flange	Large Diameter of Hub	Small Diameter of Hub	Length of Hub	Radius of Hub	Diameter of Bolt Circle	Number of Bolts	Diameter of Bolts	Diameter of Bolt Holes	Bolt Hole Tolerance (see note)	Minimum Length of Stud Bolts	Ring Number
	B	D	D	C	F	T	A	E	L	R	P						BX
10 000 psi																	
1 ³ / ₁₆	1.84	7.38	±0.06	0.12	4.12	1.66	3.50	2.56	1.91	0.38	5.75	8	¾	0.88	+0.06	5.00	151
2 ¹ / ₁₆	2.09	7.88	±0.06	0.12	4.38	1.73	3.94	2.94	2.03	0.38	6.25	8	¾	0.88	+0.06	5.20	152
2 ³ / ₁₆	2.59	9.12	±0.06	0.12	5.19	2.02	4.75	3.62	2.25	0.38	7.25	8	7/8	1.00	+0.06	6.00	153
3 ¹ / ₁₆	3.09	10.62	±0.06	0.12	6.00	2.30	5.59	4.34	2.50	0.38	8.50	8	1	1.12	+0.06	6.75	154
4 ¹ / ₁₆	4.09	12.44	±0.06	0.12	7.28	2.77	7.19	5.75	2.88	0.38	10.19	8	1 1/8	1.25	+0.06	8.00	155
5 ¹ / ₁₆	5.16	14.06	±0.06	0.12	8.69	3.12	8.81	7.19	3.19	0.38	11.81	12	1 1/8	1.25	+0.06	8.75	169
7 ¹ / ₁₆	7.09	18.88	±0.12	0.25	11.88	4.06	11.88	10.00	3.75	0.62	15.88	12	1 1/2	1.62	+0.09	11.25	156
9	9.03	21.75	±0.12	0.25	14.12	4.88	14.75	12.88	3.69	0.62	18.75	16	1 1/2	1.62	+0.09	13.00	157
11	11.03	25.75	±0.12	0.25	16.88	5.56	17.75	15.75	4.06	0.62	22.25	16	1 3/4	1.88	+0.09	15.00	158
13 ³ / ₁₆	13.66	30.25	±0.12	0.25	20.38	6.62	21.75	19.50	4.50	0.62	26.50	20	1 7/8	2.00	+0.09	17.25	159
16 ³ / ₁₆	16.78	34.31	±0.12	0.25	22.69	6.62	25.81	23.69	3.00	0.75	30.56	24	1 7/8	2.00	+0.09	17.50	162
18 ³ / ₁₆	18.78	40.94	±0.12	0.25	27.44	8.78	29.62	26.56	6.12	0.62	36.44	24	2 1/4	2.38	+0.09	22.50	164
21 ¹ / ₄	21.28	45.00	±0.12	0.25	30.75	9.50	33.38	30.00	6.50	0.81	40.25	24	2 1/2	2.62	+0.09	24.50	166

GENERAL NOTES: Dimensions are in inches. Minimum Bolt Hole Tolerance is - 0.02"

TYPE 6BX INTEGRAL FLANGES FOR 15 000 psi RATED WORKING PRESSURE

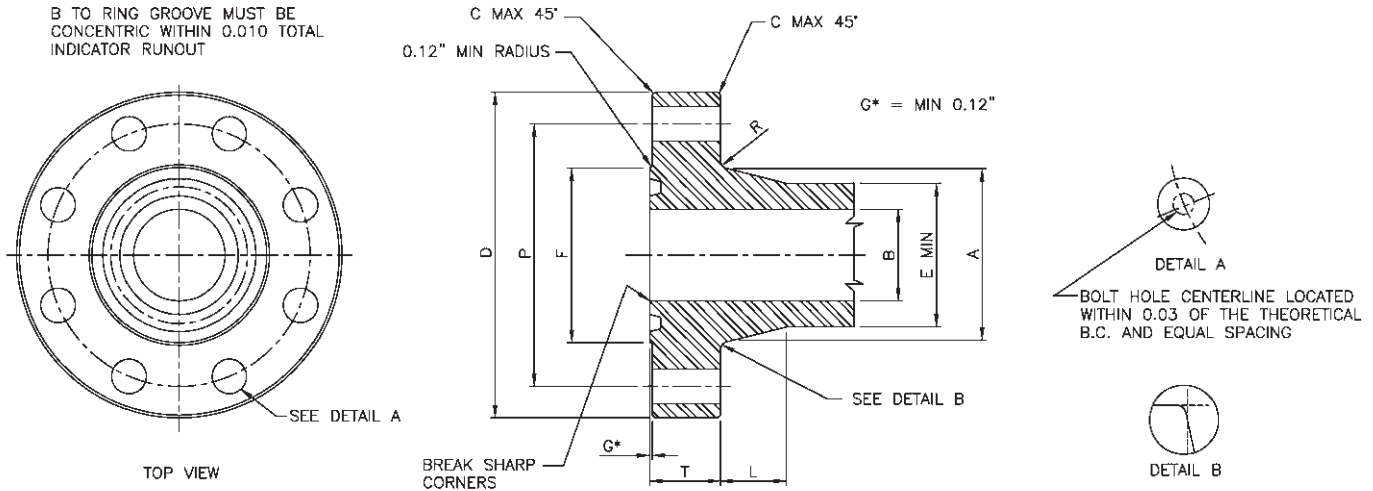

HUB AND FLANGE DIMENSIONS

Nominal Size and Bore of Flange	Maximum Bore	Outside Diameter of Flange	Tolerance	Maximum Chamfer	Diameter of Raised Face	Total Thickness of Flange	Large Diameter of Hub	Small Diameter of Hub	Length of Hub	Radius of Hub	Diameter of Bolt Circle	Number of Bolts	Diameter of Bolts	Diameter of Bolt Holes	Bolt Hole Tolerance (see note)	Minimum Length of Stud Bolts	Ring Number
B	D	D	C	F	T	A	E	L	R	P							BX
15 000 psi																	
1 $\frac{3}{16}$	1.84	8.19	±0.06	0.12	4.19	1.78	3.84	2.81	1.88	0.38	6.31	8	7/8	1.00	+0.06	5.50	151
2 $\frac{1}{16}$	2.09	8.75	±0.06	0.12	4.50	2.00	4.38	3.25	2.12	0.38	6.88	8	7/8	1.00	+0.06	6.00	152
2 $\frac{3}{16}$	2.59	10.00	±0.06	0.12	5.25	2.25	5.06	3.94	2.25	0.38	7.88	8	1	1.12	+0.06	6.75	153
3 $\frac{1}{16}$	3.09	11.31	±0.06	0.12	6.06	2.53	6.06	4.81	2.50	0.38	9.06	8	1 $\frac{1}{8}$	1.25	+0.06	7.50	154
4 $\frac{1}{16}$	4.09	14.19	±0.06	0.12	7.62	3.09	7.69	6.25	2.88	0.38	11.44	8	1 $\frac{3}{8}$	1.50	+0.06	9.25	155
5 $\frac{1}{16}$	5.16	16.50	±0.06	0.12	8.88	3.88	9.62	7.88	3.22	0.62	13.50	12	1 $\frac{1}{2}$	1.62	+0.09	11.50	169
7 $\frac{1}{16}$	7.09	19.88	±0.12	0.25	12.00	4.69	12.81	10.88	2.62	0.62	16.88	16	1 $\frac{1}{2}$	1.62	+0.09	12.75	156
9	9.03	25.50	±0.12	0.25	15.00	5.75	17.00	13.75	4.88	0.62	21.75	16	1 $\frac{7}{8}$	2.00	+0.09	15.75	157
11	11.03	32.00	±0.12	0.25	17.88	7.38	23.00	16.81	9.28	0.62	28.00	20	2	2.12	+0.09	19.25	158
13 $\frac{1}{16}$	13.66	34.88	±0.12	0.25	21.31	8.06	23.44	20.81	4.50	1.00	30.38	20	2 $\frac{1}{4}$	2.38	+0.09	21.25	159
18 $\frac{1}{16}$	18.78	45.75	±0.12	0.25	28.44	10.06	32.00	28.75	6.12	1.00	40.00	20	3	3.12	+0.12	26.75	164

GENERAL NOTES: Dimensions are in inches. Minimum Bolt Hole Tolerance is - 0.02"

TYPE 6BX INTEGRAL FLANGES FOR 20 000 psi RATED WORKING PRESSURE

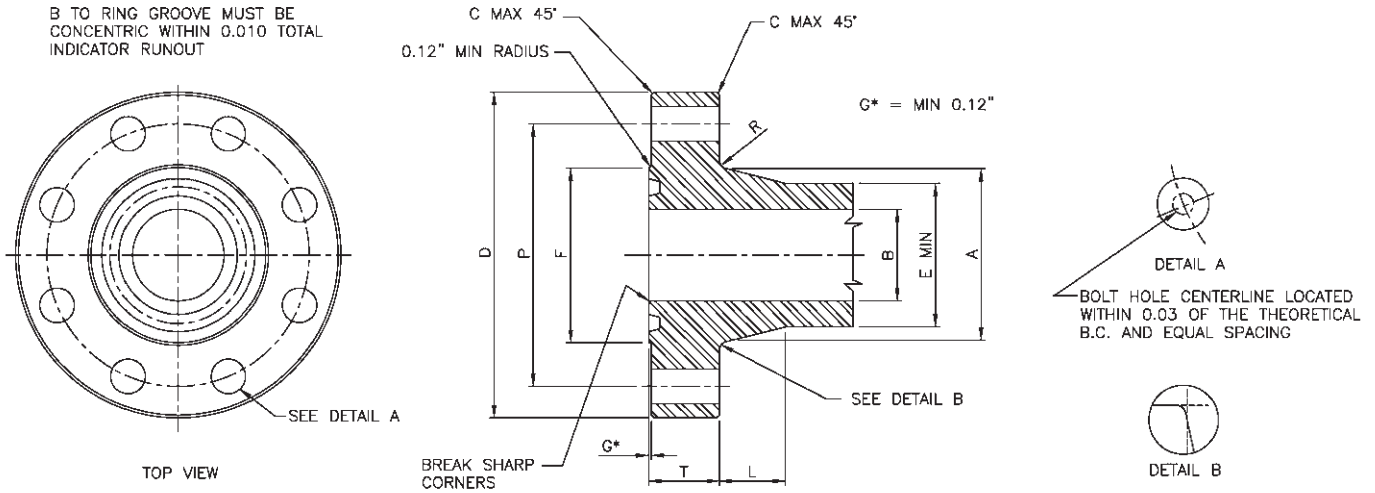

HUB AND FLANGE DIMENSIONS

Nominal Size and Bore of Flange	Maximum Bore	Outside Diameter of Flange	Tolerance	Maximum Chamfer	Diameter of Raised Face	Total Thickness of Flange	Large Diameter of Hub	Small Diameter of Hub	Length of Hub	Radius of Hub	Diameter of Bolt Circle	Number of Bolts	Diameter of Bolts	Diameter of Bolt Holes	Bolt Hole Tolerance (see note)	Minimum Length of Stud Bolts	Ring Number
B	D	D	C	F	T	A	E	L	R	P							BX
20 000 psi																	
1 ³ / ₁₆	1.84	10.12	±0.06	0.12	4.62	2.50	5.25	4.31	1.94	0.38	8.00	8	1	1.12	+0.06	7.50	151
2 ¹ / ₁₆	2.09	11.31	±0.06	0.12	5.19	2.81	6.06	5.00	2.06	0.38	9.06	8	1 ¹ / ₈	1.25	+0.06	8.25	152
2 ³ / ₁₆	2.59	12.81	±0.06	0.12	5.94	3.12	6.81	5.69	2.31	0.38	10.31	8	1 ¹ / ₄	1.38	+0.06	9.25	153
3 ¹ / ₁₆	3.09	14.06	±0.06	0.12	6.75	3.38	7.56	6.31	2.50	0.38	11.31	8	1 ³ / ₈	1.50	+0.06	10.00	154
4 ¹ / ₁₆	4.09	17.56	±0.06	0.12	8.62	4.19	9.56	8.12	2.88	0.38	14.06	8	1 ³ / ₄	1.88	+0.09	12.25	155
7 ¹ / ₁₆	7.09	25.81	±0.12	0.25	13.88	6.50	15.19	13.31	3.81	0.62	21.81	16	2	2.12	+0.09	17.50	156
9	9.03	31.69	±0.12	0.25	17.38	8.06	18.94	16.88	4.25	1.00	27.00	16	2 ¹ / ₂	2.62	+0.09	22.38	157
11	11.03	34.75	±0.12	0.25	19.88	8.81	22.31	20.00	4.06	1.00	29.50	16	2 ³ / ₄	2.88	+0.09	23.75	158
13 ³ / ₁₆	13.66	45.75	±0.12	0.25	24.19	11.50	27.31	24.75	5.25	1.00	40.00	20	3	3.12	+0.12	30.00	159

GENERAL NOTES: Dimensions are in inches. Minimum Bolt Hole Tolerance is - 0.02"

TYPE 6BX WELDING NECK FLANGES FOR 10 000 psi RATED WORKING PRESSURE

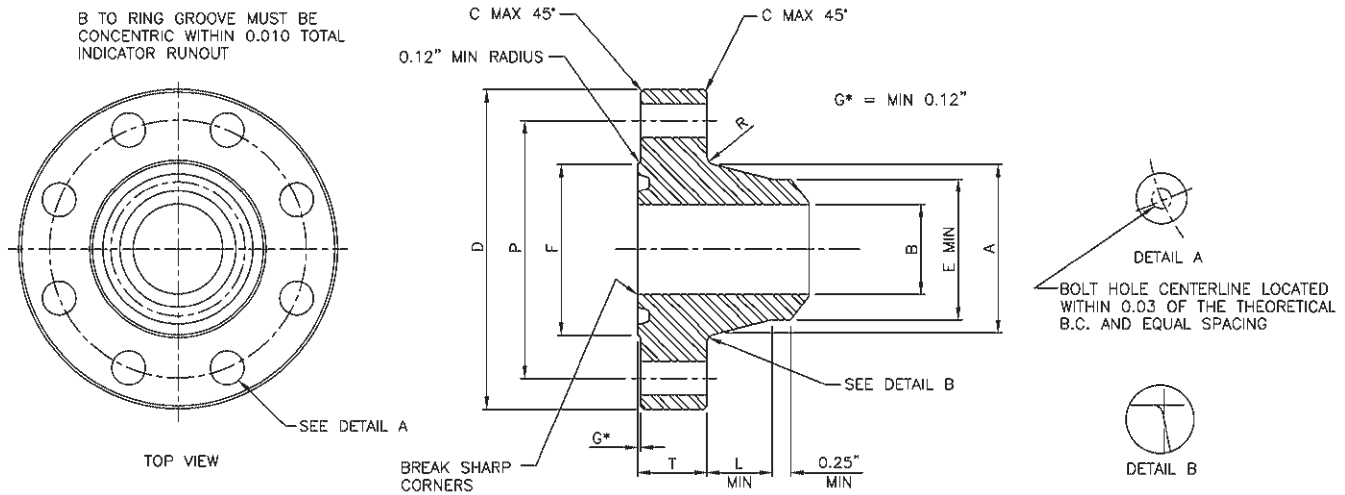

HUB AND FLANGE DIMENSIONS

Nominal Size and Bore of Flange	Maximum Bore	Outside Diameter of Flange	Tolerance	Maximum Chamfer	Diameter of Raised Face	Total Thickness of Flange	Large Diameter of Hub	Small Diameter of Hub	Length of Hub	Radius of Hub	Diameter of Bolt Circle	Number of Bolts	Diameter of Bolts	Diameter of Bolt Holes	Bolt Hole Tolerance (see note)	Minimum Length of Stud Bolts	Ring Number
B	D	D	C	F	T	A	E	L	R	P							BX
10 000 psi																	
1 ³ / ₁₆	1.84	7.38	±0.06	0.12	4.12	1.66	3.50	2.56	1.91	0.38	5.75	8	¾	.88	+0.06	5.00	151
2 ¹ / ₁₆	2.09	7.88	±0.06	0.12	4.38	1.73	3.94	2.94	2.03	0.38	6.25	8	¾	.88	+0.06	5.25	152
2 ³ / ₁₆	2.59	9.12	±0.06	0.12	5.19	2.02	4.75	3.62	2.25	0.38	7.25	8	7/8	1.00	+0.06	6.00	153
3 ¹ / ₁₆	3.09	10.62	±0.06	0.12	6.00	2.30	5.59	4.34	2.50	0.38	8.50	8	1	1.12	+0.06	6.75	154
4 ¹ / ₁₆	4.09	12.44	±0.06	0.12	7.28	2.77	7.19	5.75	2.88	0.38	10.19	8	1 ¹ / ₈	1.25	+0.06	8.00	155
5 ¹ / ₁₆	5.16	14.06	±0.06	0.12	8.69	3.13	8.81	7.19	3.19	0.38	11.81	12	1 ¹ / ₂	1.25	+0.06	8.75	169
7 ¹ / ₁₆	7.09	18.88	±0.12	0.25	11.88	4.06	11.88	10.00	3.75	0.62	15.88	12	1 ¹ / ₂	1.62	+0.09	11.25	156
9	9.03	21.75	±0.12	0.25	14.12	4.88	14.75	12.88	3.69	0.62	18.75	16	1 ¹ / ₂	1.62	+0.09	13.00	157
11	11.03	25.75	±0.12	0.25	16.88	5.56	17.75	15.75	4.06	0.62	22.25	16	1 ³ / ₄	1.88	+0.09	15.00	158
13 ³ / ₁₆	13.66	30.25	±0.12	0.25	20.38	6.62	21.75	19.50	4.50	0.62	26.50	20	1 ⁷ / ₈	2.00	+0.09	17.25	159
16 ³ / ₁₆	16.78	34.31	±0.12	0.25	22.69	6.62	25.81	23.69	3.00	0.75	30.56	24	1 ⁷ / ₈	2.00	+0.09	17.50	162

GENERAL NOTES: Dimensions are in inches. Minimum Bolt Hole Tolerance is - 0.02"
Available with a transition from 4130 to LF2

TYPE 6BX WELDING NECK FLANGES FOR 15 000 and 20 000 psi RATED WORKING PRESSURE

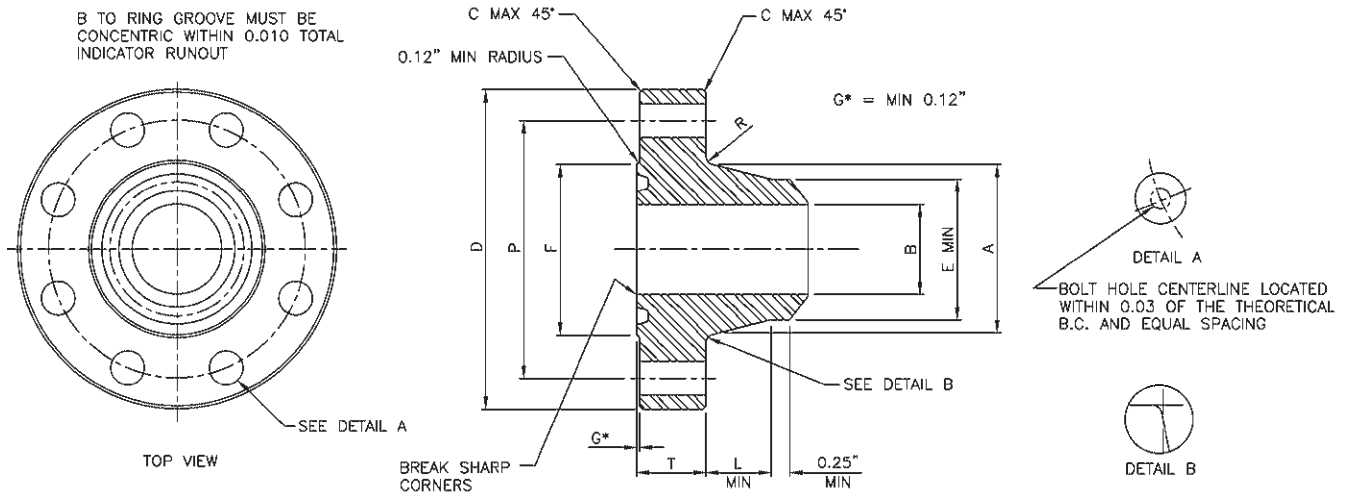

HUB AND FLANGE DIMENSIONS

Nominal Size and Bore of Flange	Maximum Bore	Outside Diameter of Flange	Tolerance	Maximum Chamfer	Diameter of Raised Face	Total Thickness of Flange	Large Diameter of Hub	Small Diameter of Hub	Length of Hub	Radius of Hub	Diameter of Bolt Circle	Number of Bolts	Diameter of Bolts	Diameter of Bolt Holes	Bolt Hole Tolerance (see note)	Minimum Length of Stud Bolts	Ring Number
B	D	D	C	F	T	A	E	L	R	P							BX
15 000 psi																	
1 ³ / ₁₆	1.84	8.19	±0.06	0.12	4.19	1.78	3.84	2.81	1.88	0.38	6.31	8	7/8	1.00	+0.06	5.50	151
2 ¹ / ₁₆	2.09	8.75	±0.06	0.12	4.50	2.00	4.38	3.25	2.12	0.38	6.88	8	7/8	1.00	+0.06	6.00	152
2 ⁵ / ₁₆	2.59	10.00	±0.06	0.12	5.25	2.25	5.06	3.94	2.25	0.38	7.88	8	1	1.12	+0.06	6.75	153
3 ¹ / ₁₆	3.09	11.31	±0.06	0.12	6.06	2.53	6.06	4.81	2.50	0.38	9.06	8	1 ¹ / ₈	1.25	+0.06	7.50	154
4 ¹ / ₁₆	4.09	14.19	±0.06	0.12	7.62	3.09	7.69	6.25	2.88	0.38	11.44	8	1 ³ / ₈	1.50	+0.06	9.25	155
5 ¹ / ₈	5.16	16.50	±0.06	0.12	8.88	3.88	9.62	7.88	3.22	0.62	13.50	12	1 ¹ / ₂	1.62	+0.09	11.50	169
7 ¹ / ₁₆	7.09	19.88	±0.12	0.25	12.00	4.69	12.81	10.88	3.62	0.62	16.88	16	1 ¹ / ₂	1.62	+0.09	12.75	156
20 000 psi																	
1 ³ / ₁₆	1.84	10.12	±0.06	0.12	4.62	2.50	5.25	4.31	1.94	0.38	8.00	8	1	1.12	+0.06	7.50	151
2 ¹ / ₁₆	2.09	11.31	±0.06	0.12	5.19	2.81	6.06	5.00	2.06	0.38	9.06	8	1 ¹ / ₈	1.25	+0.06	8.25	152
2 ⁵ / ₁₆	2.59	12.81	±0.06	0.12	5.94	3.12	6.81	5.69	2.31	0.38	10.31	8	1 ¹ / ₄	1.38	+0.06	9.25	153
3 ¹ / ₁₆	3.09	14.06	±0.06	0.12	6.75	3.38	7.56	6.31	2.50	0.38	11.31	8	1 ³ / ₈	1.50	+0.06	10.00	154
4 ¹ / ₁₆	4.09	17.56	±0.06	0.12	8.62	4.19	9.56	8.12	2.88	0.38	14.06	8	1 ³ / ₄	1.88	+0.09	12.25	155
7 ¹ / ₁₆	7.09	25.81	±0.12	0.25	13.88	6.50	15.19	13.31	3.81	0.62	21.81	16	2	2.12	+0.09	17.50	156

GENERAL NOTES: Dimensions are in inches. Minimum Bolt Hole Tolerance is - 0.02"
Available with a transition from 4130 to LF2

TYPE 6BX BLIND & TEST FLANGES FOR 10 000 and 15 000 psi RATED WORKING PRESSURE

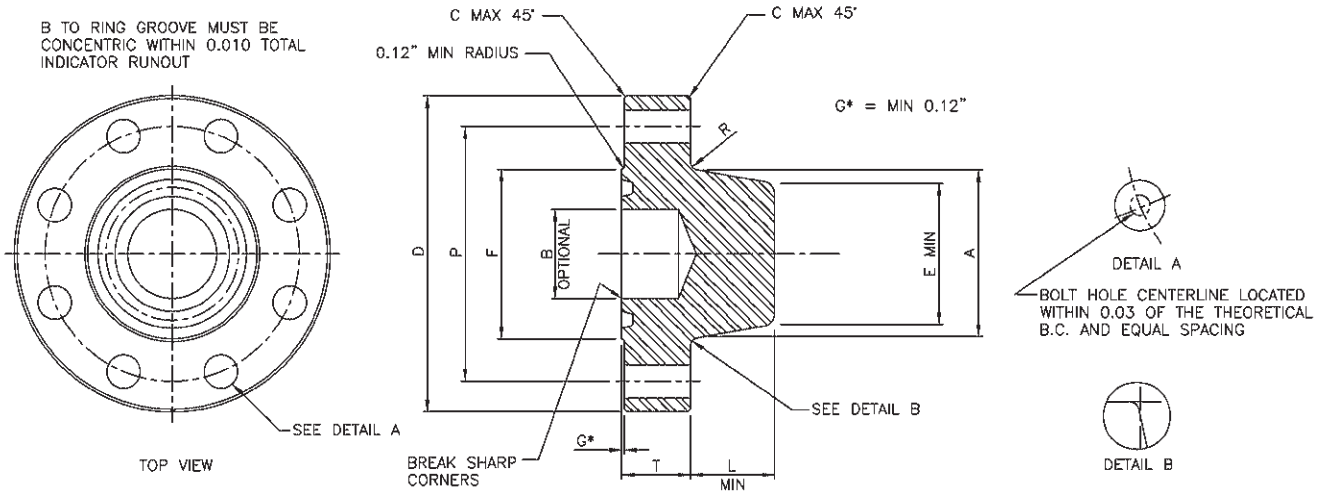

HUB AND FLANGE DIMENSIONS

Nominal Size and Bore of Flange	Maximum Bore	Outside Diameter of Flange	Tolerance	Maximum Chamfer	Diameter of Raised Face	Total Thickness of Flange	Large Diameter of Hub	Small Diameter of Hub	Length of Hub	Radius of Hub	Diameter of Bolt Circle	Number of Bolts	Diameter of Bolts	Diameter of Bolt Holes	Bolt Hole Tolerance (see note)	Minimum Length of Stud Bolts	Ring Number
B	D	D	C	F	T	A	E	L	R	P							BX
10 000 psi																	
1 ³ / ₁₆	1.84	7.38	±0.06	0.12	4.12	1.66	3.50	2.56	1.91	0.38	5.75	8	¾	.88	+0.06	5.00	151
2 ¹ / ₁₆	2.09	7.88	±0.06	0.12	4.38	1.73	3.94	2.94	2.03	0.38	6.25	8	¾	.88	+0.06	5.25	152
2 ⁵ / ₁₆	2.59	9.12	±0.06	0.12	5.19	2.02	4.75	3.62	2.25	0.38	7.25	8	7/8	1.00	+0.06	6.00	153
3 ¹ / ₁₆	3.09	10.62	±0.06	0.12	6.00	2.30	5.59	4.34	2.50	0.38	8.50	8	1	1.12	+0.06	6.75	154
4 ¹ / ₁₆	4.09	12.44	±0.06	0.12	7.28	2.77	7.19	5.75	2.88	0.38	10.19	8	1 ¹ / ₈	1.25	+0.06	8.00	155
15 000 psi																	
1 ³ / ₁₆	1.84	8.19	±0.06	0.12	4.19	1.78	3.84	2.81	1.88	0.38	6.31	8	7/8	1.00	+0.06	5.50	151
2 ¹ / ₁₆	2.09	8.75	±0.06	0.12	4.50	2.00	4.38	3.25	2.12	0.38	6.88	8	7/8	1.00	+0.06	6.00	152
2 ⁵ / ₁₆	2.59	10.00	±0.06	0.12	5.25	2.25	5.06	3.94	2.25	0.38	7.88	8	1	1.12	+0.06	6.75	153
3 ¹ / ₁₆	3.09	11.31	±0.06	0.12	6.06	2.53	6.06	4.81	2.50	0.38	9.06	8	1 ¹ / ₈	1.25	+0.06	7.50	154
4 ¹ / ₁₆	4.09	14.19	±0.06	0.12	7.62	3.09	7.69	6.25	2.88	0.38	11.44	8	1 ¹ / ₈	1.50	+0.06	9.25	155

GENERAL NOTES: Dimensions are in inches. Minimum Bolt Hole Tolerance is - 0.02"

TYPE 6BX BLIND & TEST FLANGES FOR 20 000 psi RATED WORKING PRESSURE

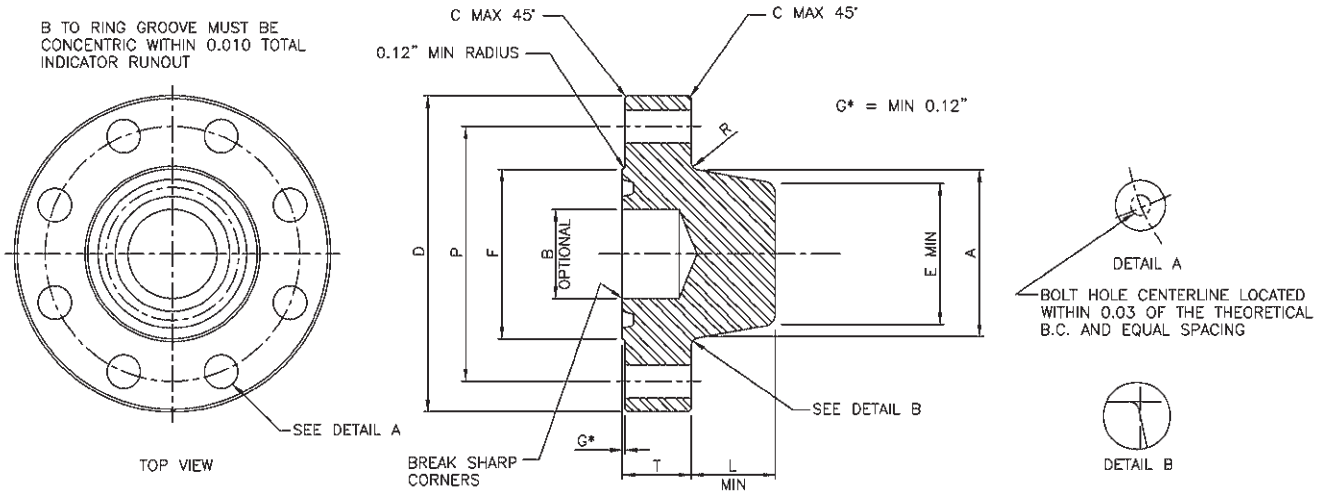

HUB AND FLANGE DIMENSIONS

Nominal Size and Bore of Flange	Maximum Bore	Outside Diameter of Flange	Tolerance	Maximum Chamfer	Diameter of Raised Face	Total Thickness of Flange	Large Diameter of Hub	Small Diameter of Hub	Length of Hub	Radius of Hub	Diameter of Bolt Circle	Number of Bolts	Diameter of Bolts	Diameter of Bolt Holes	Bolt Hole Tolerance (see note)	Minimum Length of Stud Bolts	Ring Number
		B	D	D	C	F	T	A	E	L	R	P					BX
20 000 psi																	
1 ³ / ₁₆	1.84	10.12	±0.06	0.12	4.62	2.50	5.25	4.31	1.94	0.38	8.00	8	1	1.12	+0.06	7.50	151
2 ¹ / ₁₆	2.09	11.31	±0.06	0.12	5.19	2.81	6.06	5.00	2.06	0.38	9.06	8	1 ¹ / ₈	1.25	+0.06	8.25	152
2 ⁹ / ₁₆	2.59	12.81	±0.06	0.12	5.94	3.12	6.81	5.69	2.31	0.38	10.31	8	1 ¹ / ₄	1.38	+0.06	9.25	153
3 ¹ / ₁₆	3.09	14.06	±0.06	0.12	6.75	3.38	7.56	6.31	2.50	0.38	11.31	8	1 ³ / ₈	1.50	+0.06	10.00	154
4 ¹ / ₁₆	4.09	17.56	±0.06	0.12	8.62	4.19	9.56	8.12	2.88	0.38	14.06	8	1 ³ / ₄	1.88	+0.09	12.25	155

GENERAL NOTES: Dimensions are in inches. Minimum Bolt Hole Tolerance is - 0.02"

API STUDDED CROSSES AND TEES

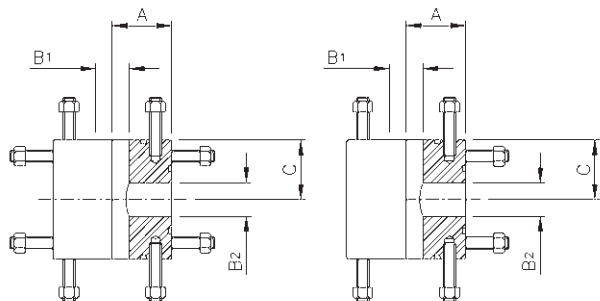

RATED WORKING PRESSURE (psi)	NOMINAL SIZE AND BORE		CENTRE TO FACE. VERTICAL RUN C	CENTRE TO FACE. HORIZONTAL RUN A
	VERTICAL B1	HORIZONTAL B2		
	[inches] + .03, -0	[inches] + .03, -0		
2,000	2 ¹ / ₁₆	2 ¹ / ₁₆	3.50	3.50
	2 ⁹ / ₁₆	2 ¹ / ₁₆	3.50	4.00
	2 ⁹ / ₁₆	2 ⁹ / ₁₆	4.50	4.50
	3 ¹ / ₈	2 ¹ / ₁₆	3.50	4.50
	3 ¹ / ₈	2 ⁹ / ₁₆	4.50	4.50
	3 ¹ / ₈	3 ¹ / ₈	4.50	4.50
	4 ¹ / ₁₆	2 ¹ / ₁₆	4.50	5.50
	4 ¹ / ₁₆	2 ⁹ / ₁₆	4.50	5.50
	4 ¹ / ₁₆	3 ¹ / ₈	4.50	5.50
	4 ¹ / ₁₆	4 ¹ / ₁₆	5.50	5.50
3,000	3 ¹ / ₈	2 ¹ / ₁₆	4.50	5.00
	3 ¹ / ₈	2 ⁹ / ₁₆	5.00	5.00
	3 ¹ / ₈	3 ¹ / ₈	5.00	5.00
	4 ¹ / ₁₆	2 ¹ / ₁₆	4.50	6.12
	4 ¹ / ₁₆	2 ⁹ / ₁₆	5.00	6.12
	4 ¹ / ₁₆	3 ¹ / ₈	5.00	6.12
	4 ¹ / ₁₆	4 ¹ / ₁₆	6.12	6.12
	4 ¹ / ₁₆	4 ¹ / ₁₆	6.12	6.12
5,000	2 ¹ / ₁₆	2 ¹ / ₁₆	4.50	4.50
	2 ⁹ / ₁₆	2 ¹ / ₁₆	4.50	5.00
	2 ⁹ / ₁₆	2 ⁹ / ₁₆	5.00	5.00
	3 ¹ / ₈	2 ¹ / ₁₆	4.50	5.50
	3 ¹ / ₈	2 ⁹ / ₁₆	5.50	5.50
	3 ¹ / ₈	3 ¹ / ₈	5.50	5.50
	4 ¹ / ₁₆	2 ¹ / ₁₆	4.50	6.50
	4 ¹ / ₁₆	2 ⁹ / ₁₆	5.00	6.50
	4 ¹ / ₁₆	3 ¹ / ₈	5.50	6.50
	4 ¹ / ₁₆	4 ¹ / ₁₆	6.50	6.50
10 000	1 ¹³ / ₁₆	1 ¹³ / ₁₆	4.38	4.38
	2 ¹ / ₁₆	1 ¹³ / ₁₆	4.38	4.38
	2 ¹ / ₁₆	2 ¹ / ₁₆	4.38	4.38
	2 ⁹ / ₁₆	1 ¹³ / ₁₆	4.50	5.12
	2 ⁹ / ₁₆	2 ¹ / ₁₆	4.50	5.12

RATED WORKING PRESSURE (psi)	NOMINAL SIZE AND BORE		CENTRE TO FACE. VERTICAL RUN C	CENTRE TO FACE. HORIZONTAL RUN A
	VERTICAL B1	HORIZONTAL B2		
	[inches] + .03, -0	[inches] + .03, -0		
10 000	2 ⁹ / ₁₆	2 ⁹ / ₁₆	5.12	5.12
	3 ¹ / ₁₆	1 ¹³ / ₁₆	4.50	5.88
	3 ¹ / ₁₆	2 ¹ / ₁₆	4.50	5.88
	3 ¹ / ₁₆	2 ⁹ / ₁₆	5.12	5.88
	3 ¹ / ₁₆	3 ¹ / ₁₆	5.88	5.88
	4 ¹ / ₁₆	1 ¹³ / ₁₆	4.50	6.88
	4 ¹ / ₁₆	2 ⁹ / ₁₆	4.50	6.88
	4 ¹ / ₁₆	2 ⁹ / ₁₆	5.12	6.88
	4 ¹ / ₁₆	3 ¹ / ₁₆	5.88	6.88
	4 ¹ / ₁₆	4 ¹ / ₁₆	6.88	6.88
15 000	1 ¹³ / ₁₆	1 ¹³ / ₁₆	5.00	5.00
	2 ¹ / ₁₆	1 ¹³ / ₁₆	5.00	5.00
	2 ¹ / ₁₆	2 ¹ / ₁₆	5.00	5.00
	2 ⁹ / ₁₆	1 ¹³ / ₁₆	5.50	5.50
	2 ⁹ / ₁₆	2 ¹ / ₁₆	5.50	5.50
	2 ⁹ / ₁₆	2 ⁹ / ₁₆	5.50	5.50
	3 ¹ / ₁₆	1 ¹³ / ₁₆	6.31	6.31
	3 ¹ / ₁₆	2 ¹ / ₁₆	6.31	6.31
	3 ¹ / ₁₆	2 ⁹ / ₁₆	6.31	6.31
	3 ¹ / ₁₆	3 ¹ / ₁₆	6.31	6.31
	4 ¹ / ₁₆	1 ¹³ / ₁₆	7.62	7.62
	4 ¹ / ₁₆	2 ¹ / ₁₆	7.62	7.62
	4 ¹ / ₁₆	2 ⁹ / ₁₆	7.62	7.62
	4 ¹ / ₁₆	3 ¹ / ₁₆	7.62	7.62
	4 ¹ / ₁₆	4 ¹ / ₁₆	7.62	7.62
	20 000	1 ¹³ / ₁₆	1 ¹³ / ₁₆	6.47
2 ¹ / ₁₆		1 ¹³ / ₁₆	6.47	6.47
2 ¹ / ₁₆		2 ¹ / ₁₆	6.47	6.47
2 ⁹ / ₁₆		1 ¹³ / ₁₆	7.28	7.28
2 ⁹ / ₁₆		2 ¹ / ₁₆	7.28	7.28
2 ⁹ / ₁₆		2 ⁹ / ₁₆	7.28	7.28
3 ¹ / ₁₆		1 ¹³ / ₁₆	7.97	7.97
3 ¹ / ₁₆		2 ¹ / ₁₆	7.97	7.97
3 ¹ / ₁₆		2 ⁹ / ₁₆	7.97	7.97
3 ¹ / ₁₆		3 ¹ / ₁₆	7.97	7.97
4 ¹ / ₁₆		1 ¹³ / ₁₆	9.91	9.91
4 ¹ / ₁₆		2 ¹ / ₁₆	9.91	9.91
4 ¹ / ₁₆		2 ⁹ / ₁₆	9.91	9.91
4 ¹ / ₁₆		3 ¹ / ₁₆	9.91	9.91
4 ¹ / ₁₆	4 ¹ / ₁₆	9.91	9.91	

GENERAL NOTES: Dimensions are in inches

HAMMER UNIONS

FIGURE 50

- Recommended for air, water, oil or gas service to 500 PSI
- Available in threaded
- Available in bronze, based on application

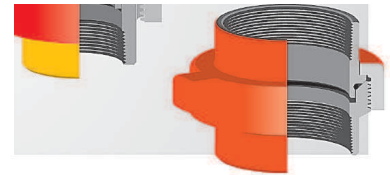

FIGURE 100

- Cold working pressure -1,000 PSI
- Low pressure union
- Manifold & general service



FIGURE 200

- Cold working pressure- 2,000 PSI
- General purpose union
- Available in threaded & butt-weld

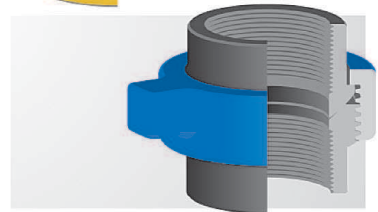

FIGURE 206

- Cold working pressure - 2,000 PSI
- O-Ring in metalsub sealing extends life
- Cup and cone provide "zero clearance against extrusion"
- Available in threaded & butt-weld
- All sizes available in sour service
- Available socketweld unions in 2", 3", 4", & 6"



FIGURE 207

- Cold working pressure - 2,000 PSI
- Manifold and blanking the end of line - 'O' ring cap provides leak-free seal
- Connection cap can be tapped for pressure gauge or valve
- Available in threaded & butt-weld

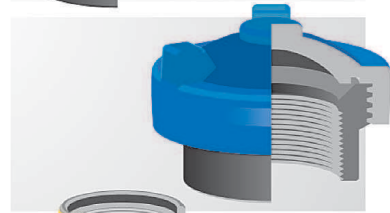
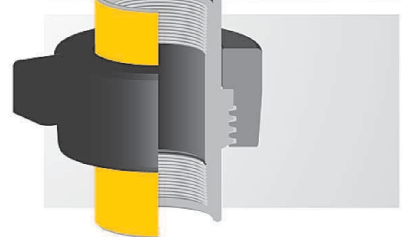

FIGURE 300

- Cold working pressure- 2,000 PSI or 6,000 PSI
- 'Flat Face' design facilitates straight breakout of connected components such as valve or fittings for repair or inspection
- Moderate vacuum service insulated unions available



HAMMER UNIONS

FIGURE 400

- 2" to 4" sizes CWP is 4,000 PSI
- 6" to 12" sizes CWP is 2,500 PSI
- Mainly used for manifold pumping and mud pumping

FIGURE 602

- Cold working pressure - 6,000 PSI
- Lip type elastomer seal protects metal-to-metal designed to reduce turbulence in the line
- Usage mainly in manifold and mud services
- Available with non-pressure thread sealing ends

FIGURE 1002

- Cold working pressure -10,000 PSI
- Field replaceable lip type elastomer seal protects secondary metal-to-metal seal
- 5" and 6" butt-weld are 7,500 PSI for standard service
- 5" and 6" butt-weld are 5,000 PSI for sour service

FIGURE 1003

- Cold working pressure -10,000 PSI
- Misaligning unions are used in high pressure applications where the lines are not aligned
- 5" is 7,500 PSI for standard service
- 5" is 5,000 PSI for sour service

FIGURE 1004

- Cold working pressure -10,000 PSI
- Field replaceable lip type elastomer seal protects secondary metal-to-metal seal
- Available in forged steel for butt-weld connections
- Schedule XXH

FIGURE 1502

- Cold working pressure -15,000 PSI
- Field replaceable lip type elastomer seal protects secondary metal-to-metal seal
- Used mainly in choke I kill lines, cementing, fracturing I testing
- Available in threaded, welded, butt-weld and non-pressure thread sealing ends

FIGURE 2202

- Cold working pressure -15,000 PSI
- Field replaceable lip type elastomer seal protects secondary metal-to-metal seal
- Used in sour gas services
- Meets Nace MR-01-75 standards
- Butt-weld Schedule XXH only

