

API FLANGES

SECTION 4a API 6A TYPE 6B, 6BX Flanges and Studded Crosses and Tees

Flanges and Studded Blocks are designed and manufactured in accordance with the following specifications:-

API 6A	Specification for Wellhead and Christmas Tree Equipment.
ANSI B31.3	Chemical Plant and Petroleum Refinery Piping.
ASME VIII	Boiler and Pressure Vessel Code.
MSS-SP-55	Quality Standards for Steel Castings for Valves, Flanges and Fittings and other Piping Components.
NACE MR-01-75	Sulphide Stress Cracking Resistant Metallic Materials for Oilfield Equipment.

Flanges are available as Weld Neck, Integral, Blinds, Target & Test Blinds for use with the following pressure ratings:-

MAX. WORKING PRESSURE	2,000 PSI	3000 PSI	5,000 PSI	10,000 PSI	2000 PSI	2000 PSI
TEST PRESSURE	3,000 PSI	4,500 PSI	7,500 PSI	15,000 PSI	22,000 PSI	30,000 PSI
PRODUCT SPECIFICATION LEVELS	1,2,3	1,2,3	1,2,3	1,2,3	1,2,3	1,2,3
API TEMPERATURE RATING	K (-60 DEG C) TO Y (+345 DEG C)	K (-60 DEG C) TO Y (+345 DEG C)	K (-60 DEG C) TO Y (+345 DEG C)	K (-60 DEG C) TO Y (+345 DEG C)	K (-60 DEG C) TO Y (+345 DEG C)	K (-60 DEG C) TO Y (+345 DEG C)
INTEGRAL, BLIND, TARGET BLIND & TEST FLANGES AND STUDED BLOCKS						
MIN. YIELD	60,000 PSI	60,000 PSI	60,000 PSI	60,000 PSI	75,000 PSI	75,000 PSI
MIN. TENSILE MATERIAL	85,000 PSI API 60K	85,000 PSI API 60K	85,000 PSI API 60K	85,000 PSI API 60K	95,000 PSI API 75K	95,000 PSI API 75K
WELD NECK FLANGES						
MIN. YIELD	45,000 PSI	45,000 PSI	45,000 PSI	60,000 PSI	75,000 PSI	75,000 PSI
MIN. TENSILE MATERIAL	70,000 PSI API 45K	70,000 PSI API 45K	70,000 PSI API 45K	85,000 PSI API 60K	95,000 PSI API 75K	95,000 PSI API 75K

GENERAL NOTES: Max. working pressures stated are suitable for temperatures up to 121°C.
De-rating of max. working pressure will occur as the operating temperature increases above 121°C.

TYPE 6B FLANGES FOR 2000 psi RATED WORKING PRESSURE

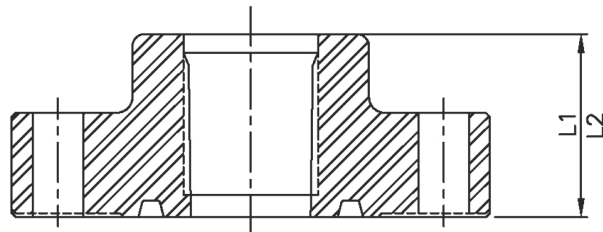

THREADED FLANGE

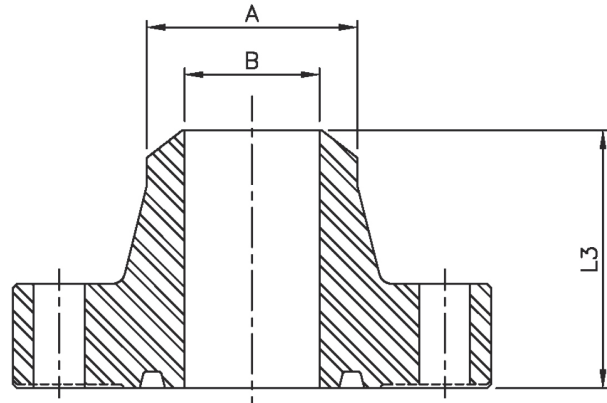

WELD NECK LINE PIPE FLANGE

HUB AND BORE DIMENSIONS

Nominal Size and Bore of Flange	Hub Length Threaded Line-Pipe Flange	Hub Length Threaded Casing Flange	Hub Length Welding Neck Line-Pipe Flange	Neck Diameter Welding Neck Line-Pipe Flange	Tolerance	Maximum Bore of Welding Neck Flange
	L1	L2	L3±0.06	A	A	B
2½	1.75	—	3.19	2.38	+0.09/-0.03	2.10
2¾	1.94	—	3.44	2.88	+0.09/-0.03	2.50
3⅛	2.12	—	3.56	3.50	+0.09/-0.03	3.10
4¼	2.44	3.50	4.31	4.50	+0.09/-0.03	4.06
5⅛	2.69	4.00	4.81	5.56	+0.09/-0.08	4.84
7¼	2.94	4.50	4.94	6.63	+0.16/-0.03	5.79
9	3.31	5.00	5.56	8.63	+0.16/-0.03	7.84
11	3.69	5.25	6.31	10.75	+0.16/-0.03	9.78
13⅝	3.94	3.94	—	—	—	—
16¾	4.50	4.50	—	—	—	—
21¼	5.38	5.38	—	—	—	—

GENERAL NOTES: Dimensions are in inches

TYPE 6B FLANGES FOR 2000 psi RATED WORKING PRESSURE

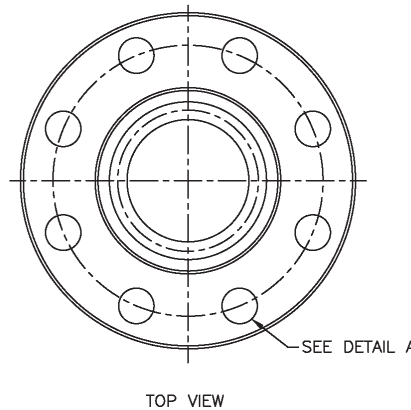
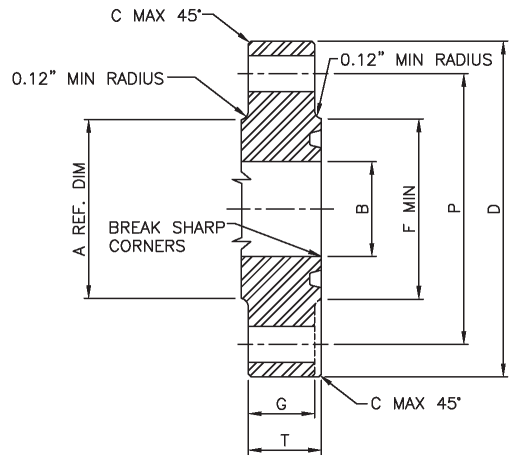

RING GROOVE MUST BE CONCENTRIC WITH BORE WITHIN 0.010 TOTAL INDICATOR RUNOUT

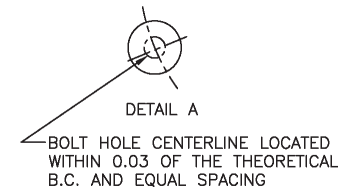

HUB AND BORE DIMENSIONS

Nominal Size and Bore of Flange	Maximum Bore	Outside Diameter of Flange	Tolerance	Maximum Chamfer	Diameter of Raised Face	Total Thickness of Flange	Basic Thickness of Flange	Diameter of Hub	Diameter of Bolt Circle	Number of Bolts	Diameter of Bolts	Diameter of Bolt Holes	Bolt Hole Tolerance (see note)	Length of Bolts	Ring number, R or RX
	B	D	D	C	F	T	G	A	P						
2 ¹ / ₁₆	2.09	6.50	±0.06	0.12	4.25	1.31	1.00	3.31	5.00	8	5/8	0.75	+0.06	4.50	23
2 ³ / ₁₆	2.59	7.50	±0.06	0.12	5.00	1.44	1.12	3.94	5.88	8	3/4	0.88	+0.06	5.00	26
3/8	3.22	8.25	±0.06	0.12	5.75	1.56	1.25	4.62	6.62	8	3/4	0.88	+0.06	5.25	31
4 ¹ / ₁₆	4.28	10.75	±0.06	0.12	6.88	1.81	1.50	6.00	8.50	8	7/8	1.00	+0.06	6.00	37
5/8	5.16	13.00	±0.06	0.12	8.25	2.06	1.75	7.44	10.50	8	1	1.12	+0.06	6.75	41
7 ¹ / ₁₆	7.16	14.00	±0.12	0.25	9.50	2.19	1.88	8.75	11.50	12	1	1.12	+0.06	7.00	45
9	9.03	16.50	±0.12	0.25	11.88	2.50	2.19	10.75	13.75	12	1 ¹ / ₈	1.25	+0.06	8.00	49
11	11.03	20.00	±0.12	0.25	14.00	2.81	2.50	13.50	17.00	16	1 ¹ / ₄	1.38	+0.06	8.75	53
13 ⁵ / ₈	13.66	22.00	±0.12	0.25	16.25	2.94	2.62	15.75	19.25	20	1 ¹ / ₄	1.38	+0.06	9.00	57
16 ³ / ₄	16.78	27.00	±0.12	0.25	20.00	3.31	3.00	19.50	23.75	20	1 ¹ / ₂	1.62	+0.09	10.25	65
21 ¹ / ₄	21.28	32.00	±0.12	0.25	25.00	3.88	3.50	24.00	28.50	24	1 ⁵ / ₈	1.75	+0.09	11.75	73

GENERAL NOTES: Dimensions are in inches. Minimum Bolt Hole Tolerance is - 0.02"

TYPE 6B FLANGES FOR 3000 psi RATED WORKING PRESSURE

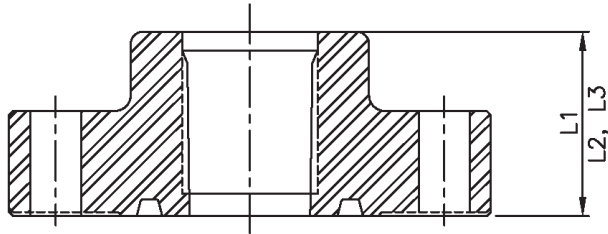

THREADED FLANGE

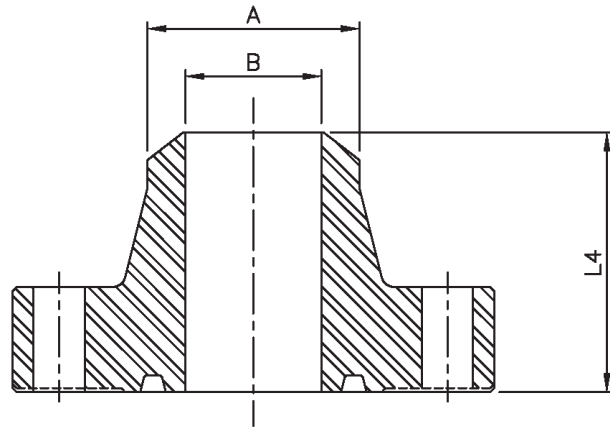

WELD NECK LINE PIPE FLANGE

HUB AND BORE DIMENSIONS

Nominal Size and Bore of Flange	Hub Length Threaded Line-Pipe Flange	Hub Length Threaded Casing Flange	Hub Length Tubing Flange	Hub Length Welding Neck Line-Pipe Flange	Neck Diameter Welding Neck Line-Pipe Flange	Tolerance	Maximum Bore of Welding Neck Flange
	L1	L2	L3	L4±0.06	A	A	B
2 ¹ / ₁₆	2.56	—	2.56	4.31	2.38	+0.09/-0.03	1.97
2 ⁹ / ₁₆	2.81	—	2.81	4.44	2.88	+0.09/-0.03	2.35
3 ¹ / ₈	2.44	—	2.94	4.31	3.50	+0.09/-0.03	2.93
4 ¹ / ₁₆	3.06	3.50	3.50	4.81	4.50	+0.09/-0.03	3.86
5 ¹ / ₈	3.44	4.00	—	5.31	5.56	+0.09/-0.03	4.84
7 ¹ / ₁₆	3.69	4.50	—	5.81	6.63	+0.016/-0.03	5.79
9	4.31	5.00	—	6.69	8.63	+0.016/-0.03	7.47
11	4.56	5.25	—	7.56	10.75	+0.016/-0.03	9.34
13 ⁵ / ₈	4.94	4.94	—	—	—	—	—
16 ³ / ₄	5.06	5.69	—	—	—	—	—
20 ³ / ₄	6.75	6.75	—	—	—	—	—

GENERAL NOTES: Dimensions are in inches

TYPE 6B FLANGES FOR 3000 psi RATED WORKING PRESSURE

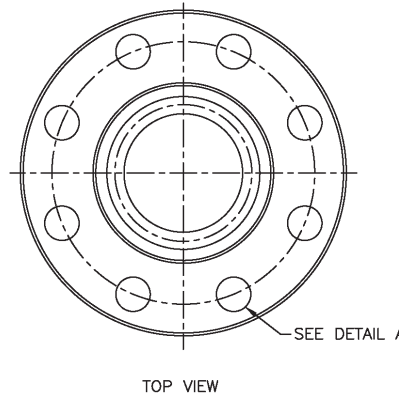
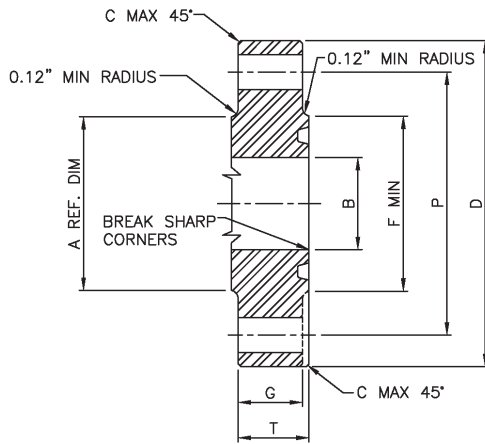

RING GROOVE MUST BE CONCENTRIC WITH BORE WITHIN 0.010 TOTAL INDICATOR RUNOUT

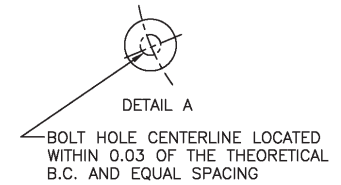

HUB AND BORE DIMENSIONS

Nominal Size and Bore of Flange	Maximum Bore	Outside Diameter of Flange	Tolerance	Maximum Chamfer	Diameter of Raised Face	Total Thickness of Flange	Basic Thickness of Flange	Diameter of Hub	Diameter of Bolt Circle	Number of Bolts	Diameter of Bolts	Diameter of Bolt Holes	Bolt Hole Tolerance (see note)	Length of Bolts	Ring number, R or RX
	B	D	D	C	F	T	G	A	P						
2 $\frac{1}{16}$	2.09	8.50	±0.06	0.12	4.88	1.81	1.50	4.12	6.50	8	7/8	1.00	+0.06	6.00	24
2 $\frac{3}{16}$	2.59	9.62	±0.06	0.12	5.38	1.94	1.62	4.88	7.50	8	1	1.12	+0.06	6.50	27
3/8	3.22	9.50	±0.06	0.12	6.12	1.81	1.50	5.00	7.50	8	7/8	1.00	+0.06	6.00	31
4 $\frac{1}{16}$	4.28	11.50	±0.06	0.12	7.12	2.06	1.75	6.25	9.25	8	1 $\frac{1}{8}$	1.25	+0.06	7.00	37
5/8	5.16	13.75	±0.06	0.12	8.50	2.31	2.00	7.50	11.00	8	1 $\frac{1}{4}$	1.38	+0.06	7.75	41
7/8	7.16	15.00	±0.12	0.25	9.50	2.50	2.19	9.25	12.50	12	1 $\frac{1}{8}$	1.25	+0.06	8.00	45
9	9.03	18.50	±0.12	0.25	12.12	2.81	2.50	11.75	15.50	12	1 $\frac{3}{8}$	1.50	+0.06	9.00	49
11	11.03	21.50	±0.12	0.25	14.25	3.06	2.75	14.50	18.50	16	1 $\frac{3}{8}$	1.50	+0.06	9.50	53
13 $\frac{5}{8}$	13.66	24.00	±0.12	0.25	16.50	3.44	3.12	16.50	21.00	20	1 $\frac{3}{8}$	1.50	+0.06	10.25	57
16 $\frac{3}{4}$	16.78	27.75	±0.12	0.25	20.62	3.94	3.50	20.00	24.25	20	1 $\frac{5}{8}$	1.75	+0.09	11.75	66
20 $\frac{3}{4}$	20.78	33.75	±0.12	0.25	25.50	4.75	4.25	24.50	29.50	20	2	2.12	+0.09	14.50	74

GENERAL NOTES: Dimensions are in inches. Minimum Bolt Hole Tolerance is - 0.02"

TYPE 6B FLANGES FOR 5000 psi RATED WORKING PRESSURE

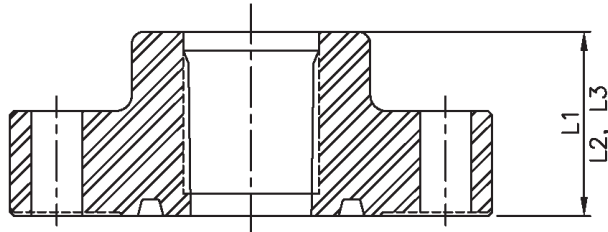

THREADED FLANGE

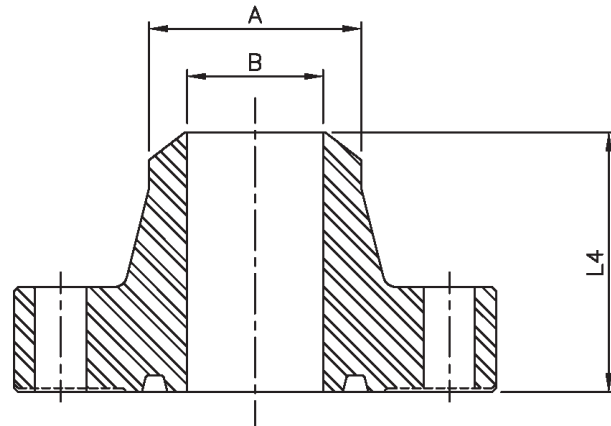

WELD NECK LINE PIPE FLANGE

HUB AND BORE DIMENSIONS

Nominal Size and Bore of Flange	Hub Length Threaded Line-Pipe Flange	Hub Length Threaded Casing Flange	Hub Length Tubing Flange	Hub Length Welding Neck Line-Pipe Flange	Neck Diameter Welding Neck Line-Pipe Flange	Tolerance	Maximum Bore of Welding Neck Flange
	L1	L2	L3	L4±0.06	A	A	B
2 ¹ / ₁₆	2.56	—	2.56	4.31	2.38	+0.09/-0.03	1.72
2 ⁹ / ₁₆	2.81	—	2.81	4.44	2.88	+0.09/-0.03	2.16
3 ¹ / ₈	3.19	—	3.19	4.94	3.50	+0.09/-0.03	2.65
4 ¹ / ₁₆	3.88	3.88	3.88	5.19	4.50	+0.09/-0.03	3.47
5 ¹ / ₈	4.44	4.44	—	6.44	5.56	+0.09/-0.03	4.34
7 ¹ / ₁₆	5.06	5.06	—	7.13	6.63	+0.016/-0.03	5.22
9	6.06	6.06	—	8.81	8.63	+0.016/-0.03	6.84
11	6.69	6.69	—	10.44	10.75	+0.016/-0.03	8.53

GENERAL NOTES: Dimensions are in inches

TYPE 6B FLANGES FOR 5000 psi RATED WORKING PRESSURE

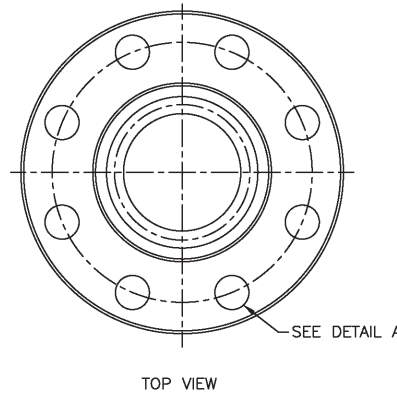
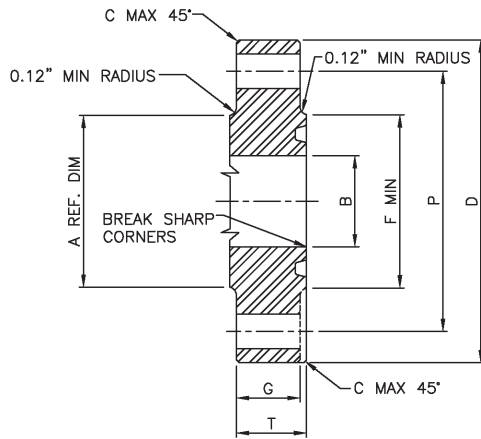

RING GROOVE MUST BE CONCENTRIC WITH BORE WITHIN 0.010 TOTAL INDICATOR RUNOUT

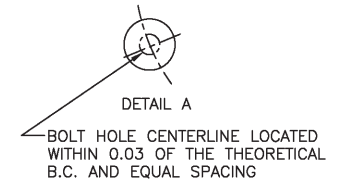

HUB AND BORE DIMENSIONS

Nominal Size and Bore of Flange	Maximum Bore	Outside Diameter of Flange	Tolerance	Maximum Chamfer	Diameter of Raised Face	Total Thickness of Flange	Basic Thickness of Flange	Diameter of Hub	Diameter of Bolt Circle	Number of Bolts	Diameter of Bolts	Diameter of Bolt Holes	Bolt Hole Tolerance (see note)	Length of Bolts	Ring number, R or RX
	B	D	D	C	F	T	G	A	P						
2 $\frac{1}{16}$	2.09	8.50	±0.06	0.12	4.88	1.81	1.50	4.12	6.50	8	$\frac{7}{8}$	1.00	+0.06	6.00	24
2 $\frac{3}{16}$	2.59	9.62	±0.06	0.12	5.38	1.94	1.62	4.88	7.50	8	1	1.12	+0.06	6.50	27
3 $\frac{1}{8}$	3.22	10.50	±0.06	0.12	6.62	2.19	1.88	5.25	8.00	8	1 $\frac{1}{8}$	1.25	+0.06	7.25	35
4 $\frac{1}{16}$	4.28	12.25	±0.06	0.12	7.62	2.44	2.12	6.38	9.50	8	1 $\frac{1}{4}$	1.38	+0.06	8.00	39
5 $\frac{1}{8}$	5.16	14.75	±0.06	0.12	9.00	3.19	2.88	7.75	11.50	8	1 $\frac{1}{2}$	1.62	+0.06	10.00	44
7 $\frac{1}{16}$	7.16	15.50	±0.12	0.25	9.75	3.62	3.25	9.00	12.50	12	1 $\frac{3}{8}$	1.50	+0.06	10.75	46
9	9.03	19.00	±0.12	0.25	12.50	4.06	3.62	11.50	15.50	12	1 $\frac{5}{8}$	1.75	+0.09	12.00	50
11	11.03	23.00	±0.12	0.25	14.63	4.69	4.25	14.50	19.00	12	1 $\frac{7}{8}$	2.00	+0.09	13.75	54

GENERAL NOTES: Dimensions are in inches. Minimum Bolt Hole Tolerance is - 0.02"

TYPE 6BX INTEGRAL FLANGES FOR 2000, 3000, and 5000 psi RATED WORKING PRESSURE

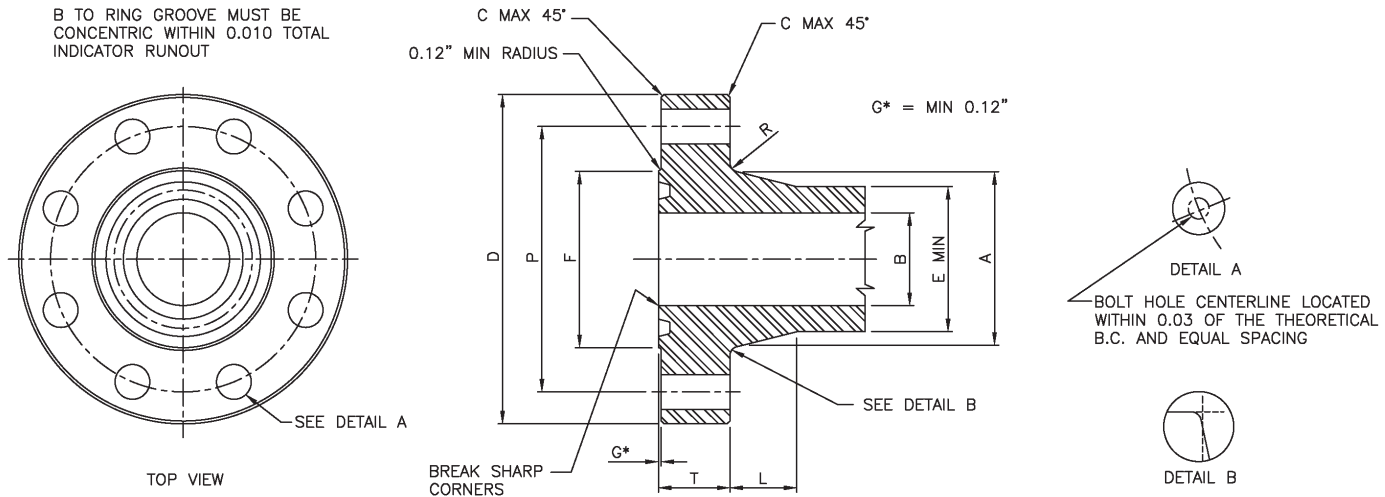

HUB AND FLANGE DIMENSIONS

Nominal Size and Bore of Flange	Maximum Bore	Outside Diameter of Flange	Tolerance	Maximum Chamfer	Diameter of Raised Face	Total Thickness of Flange	Large Diameter of Hub	Small Diameter of Hub	Length of Hub	Radius of Hub	Diameter of Bolt Circle	Number of Bolts	Diameter of Bolts	Diameter of Bolt Holes	Bolt Hole Tolerance (see note)	Minimum Length of Stud Bolts	Ring number
B	D	D	C	F	T	A	E	L	R	P							BX
2000 psi																	
26 $\frac{3}{4}$	26.78	41.00	± 0.12	0.25	31.69	4.97	32.91	29.25	7.31	0.62	37.50	20	1 $\frac{3}{4}$	1.88	+0.09	13.75	167
30	30.03	44.19	± 0.12	0.25	35.75	5.28	36.69	32.80	7.75	0.62	40.94	32	1 $\frac{1}{2}$	1.75	+0.09	14.25	303
3000 psi																	
26 $\frac{3}{4}$	26.78	43.38	± 0.12	0.25	32.75	6.34	34.25	30.56	7.31	0.62	39.38	24	2	2.12	+0.09	17.00	168
30	30.03	46.68	± 0.12	0.25	36.31	6.58	38.19	34.30	7.75	0.62	42.94	32	1 $\frac{7}{8}$	2.00	+0.09	17.75	303
5000 psi																	
13 $\frac{3}{8}$	13.66	26.50	± 0.12	0.25	18.00	4.44	18.94	16.69	4.50	0.62	23.25	16	1 $\frac{1}{2}$	1.75	+0.09	12.50	160
16 $\frac{3}{4}$	16.78	30.38	± 0.12	0.25	21.06	5.13	21.88	20.75	3.00	0.75	26.62	16	1 $\frac{1}{2}$	2.00	+0.09	14.50	162
18 $\frac{3}{4}$	18.78	35.62	± 0.12	0.25	24.69	6.53	26.56	23.56	6.00	0.62	31.62	20	2	2.12	+0.09	17.50	163
21 $\frac{1}{4}$	21.28	39.00	± 0.12	0.25	27.62	7.12	29.88	26.75	6.50	0.69	34.88	24	2	2.12	+0.09	18.75	165

GENERAL NOTES: Dimensions are in inches. Minimum Bolt Hole Tolerance is -0.02

TYPE 6BX INTEGRAL FLANGES FOR 10 000 psi RATED WORKING PRESSURE

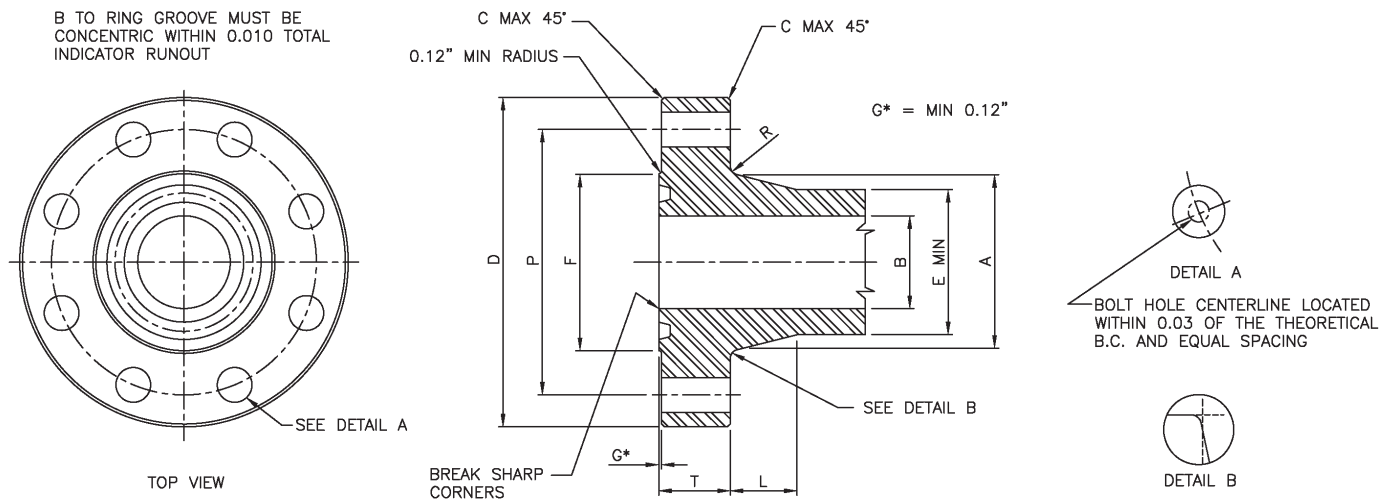

HUB AND FLANGE DIMENSIONS

Nominal Size and Bore of Flange	Maximum Bore	Outside Diameter of Flange	Tolerance	Maximum Chamfer	Diameter of Raised Face	Total Thickness of Flange	Large Diameter of Hub	Small Diameter of Hub	Length of Hub	Radius of Hub	Diameter of Bolt Circle	Number of Bolts	Diameter of Bolts	Diameter of Bolt Holes	Bolt Hole Tolerance (see note)	Minimum Length of Stud Bolts	Ring number
B	D	D	C	F	T	A	E	L	R	P							BX
10 000 psi																	
1 ³ / ₁₆	1.84	7.38	±0.06	0.12	4.12	1.66	3.50	2.56	1.91	0.38	5.75	8	3/4	0.88	+0.06	5.00	151
2 ¹ / ₁₆	2.09	7.88	±0.06	0.12	4.38	1.73	3.94	2.94	2.03	0.38	6.25	8	3/4	0.88	+0.06	5.20	152
2 ⁹ / ₁₆	2.59	9.12	±0.06	0.12	5.19	2.02	4.75	3.62	2.25	0.38	7.25	8	7/8	1.00	+0.06	6.00	153
3 ¹ / ₁₆	3.09	10.62	±0.06	0.12	6.00	2.30	5.59	4.34	2.50	0.38	8.50	8	1	1.12	+0.06	6.75	154
4 ¹ / ₁₆	4.09	12.44	±0.06	0.12	7.28	2.77	7.19	5.75	2.88	0.38	10.19	8	1 1/8	1.25	+0.06	8.00	155
5 ¹ / ₁₆	5.16	14.06	±0.06	0.12	8.69	3.12	8.81	7.19	3.19	0.38	11.81	12	1 1/8	1.25	+0.06	8.75	169
7 ¹ / ₁₆	7.09	18.88	±0.12	0.25	11.88	4.06	11.88	10.00	3.75	0.62	15.88	12	1 1/2	1.62	+0.09	11.25	156
9	9.03	21.75	±0.12	0.25	14.12	4.88	14.75	12.88	3.69	0.62	18.75	16	1 1/2	1.62	+0.09	13.00	157
11	11.03	25.75	±0.12	0.25	16.88	5.56	17.75	15.75	4.06	0.62	22.25	16	1 3/4	1.88	+0.09	15.00	158
13 ³ / ₁₆	13.66	30.25	±0.12	0.25	20.38	6.62	21.75	19.50	4.50	0.62	26.50	20	1 7/8	2.00	+0.09	17.25	159
16 ³ / ₁₆	16.78	34.31	±0.12	0.25	22.69	6.62	25.81	23.69	3.00	0.75	30.56	24	1 7/8	2.00	+0.09	17.50	162
18 ³ / ₁₆	18.78	40.94	±0.12	0.25	27.44	8.78	29.62	26.56	6.12	0.62	36.44	24	2 1/4	2.38	+0.09	22.50	164
21 ¹ / ₁₆	21.28	45.00	±0.12	0.25	30.75	9.50	33.38	30.00	6.50	0.81	40.25	24	2 1/2	2.62	+0.09	24.50	166

GENERAL NOTES: Dimensions are in inches. Minimum Bolt Hole Tolerance is - 0.02"

TYPE 6BX INTEGRAL FLANGES FOR 15 000 psi RATED WORKING PRESSURE

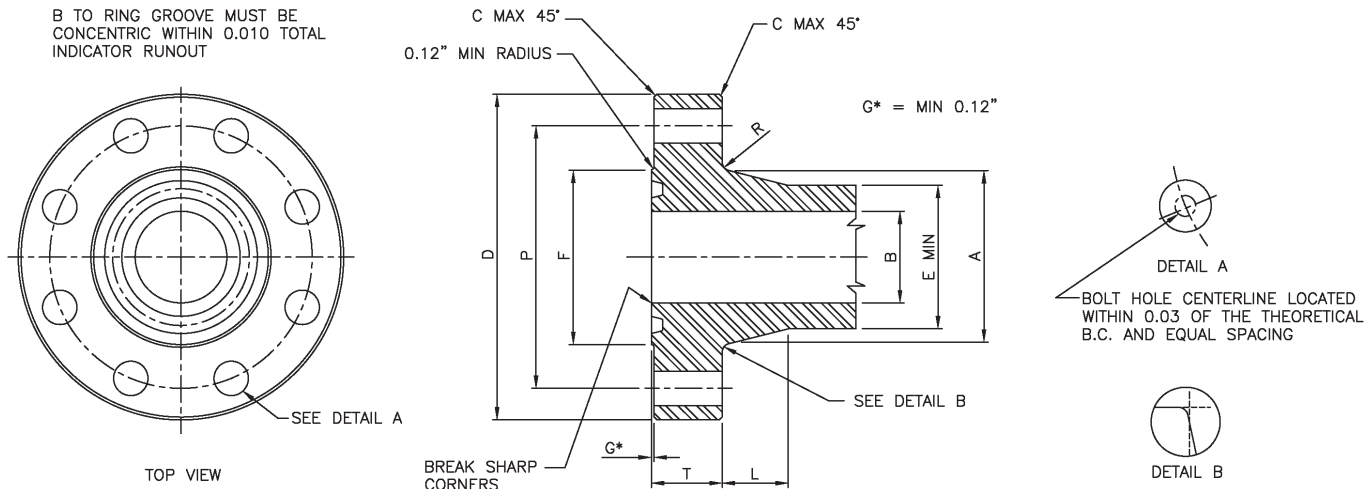

HUB AND FLANGE DIMENSIONS

Nominal Size and Bore of Flange	Maximum Bore	Outside Diameter of Flange	Tolerance	Maximum Chamfer	Diameter of Raised Face	Total Thickness of Flange	Large Diameter of Hub	Small Diameter of Hub	Length of Hub	Radius of Hub	Diameter of Bolt Circle	Number of Bolts	Diameter of Bolts	Diameter of Bolt Holes	Bolt Hole Tolerance (see note)	Minimum Length of Stud Bolts	Ring number
B	D	D	C	F	T	A	E	L	R	P							BX
15 000 psi																	
1 $\frac{3}{8}$ "	1.84	8.19	±0.06	0.12	4.19	1.78	3.84	2.81	1.88	0.38	6.31	8	7/8	1.00	+0.06	5.50	151
2 $\frac{1}{8}$ "	2.09	8.75	±0.06	0.12	4.50	2.00	4.38	3.25	2.12	0.38	6.88	8	7/8	1.00	+0.06	6.00	152
2 $\frac{9}{16}$ "	2.59	10.00	±0.06	0.12	5.25	2.25	5.06	3.94	2.25	0.38	7.88	8	1	1.12	+0.06	6.75	153
3 $\frac{1}{8}$ "	3.09	11.31	±0.06	0.12	6.06	2.53	6.06	4.81	2.50	0.38	9.06	8	1 $\frac{1}{8}$	1.25	+0.06	7.50	154
4 $\frac{1}{8}$ "	4.09	14.19	±0.06	0.12	7.62	3.09	7.69	6.25	2.88	0.38	11.44	8	1 $\frac{3}{8}$	1.50	+0.06	9.25	155
5 $\frac{1}{8}$ "	5.16	16.50	±0.06	0.12	8.88	3.88	9.62	7.88	3.22	0.62	13.50	12	1 $\frac{1}{2}$	1.62	+0.09	11.50	169
7 $\frac{1}{8}$ "	7.09	19.88	±0.12	0.25	12.00	4.69	12.81	10.88	2.62	0.62	16.88	16	1 $\frac{1}{2}$	1.62	+0.09	12.75	156
9	9.03	25.50	±0.12	0.25	15.00	5.75	17.00	13.75	4.88	0.62	21.75	16	1 $\frac{7}{8}$	2.00	+0.09	15.75	157
11	11.03	32.00	±0.12	0.25	17.88	7.38	23.00	16.81	9.28	0.62	28.00	20	2	2.12	+0.09	19.25	158
13 $\frac{3}{8}$ "	13.66	34.88	±0.12	0.25	21.31	8.06	23.44	20.81	4.50	1.00	30.38	20	2 $\frac{1}{4}$	2.38	+0.09	21.25	159
18 $\frac{3}{8}$ "	18.78	45.75	±0.12	0.25	28.44	10.06	32.00	28.75	6.12	1.00	40.00	20	3	3.12	+0.12	26.75	164

GENERAL NOTES: Dimensions are in inches. Minimum Bolt Hole Tolerance is - 0.02"

TYPE 6BX INTEGRAL FLANGES FOR 20 000 psi RATED WORKING PRESSURE

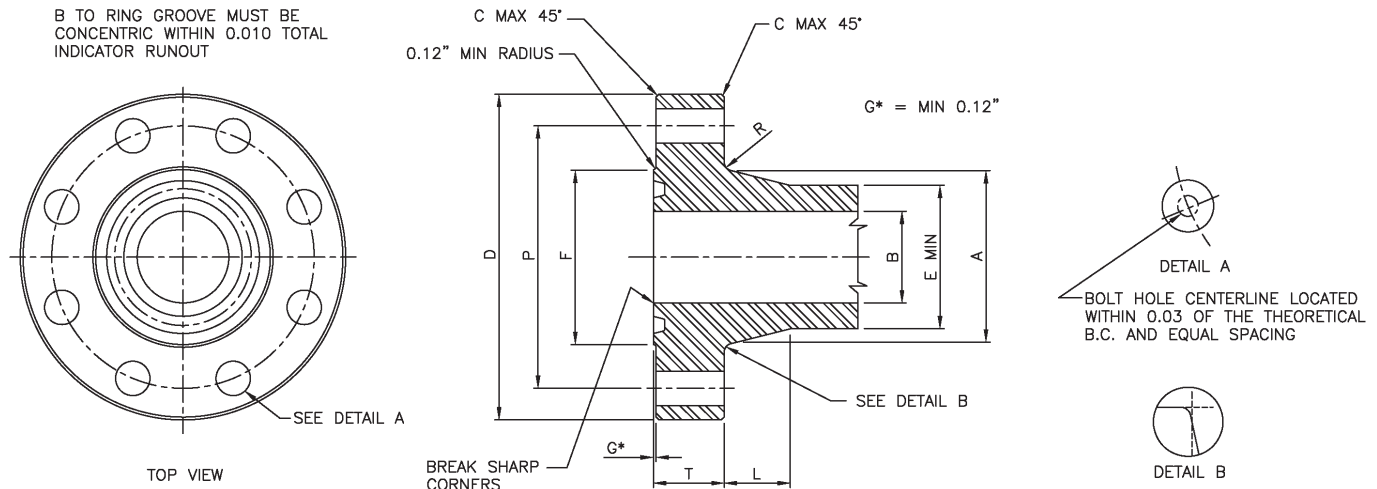

HUB AND FLANGE DIMENSIONS

Nominal Size and Bore of Flange	Maximum Bore	Outside Diameter of Flange	Tolerance	Maximum Chamfer	Diameter of Raised Face	Total Thickness of Flange	Large Diameter of Hub	Small Diameter of Hub	Length of Hub	Radius of Hub	Diameter of Bolt Circle	Number of Bolts	Diameter of Bolts	Diameter of Bolt Holes	Bolt Hole Tolerance (see note)	Minimum Length of Stud Bolts	Ring number
B	D	D	C	F	T	A	E	L	R	P							BX
20 000 psi																	
1 ³ / ₁₆	1.84	10.12	±0.06	0.12	4.62	2.50	5.25	4.31	1.94	0.38	8.00	8	1	1.12	+06	7.50	151
2 ¹ / ₁₆	2.09	11.31	±0.06	0.12	5.19	2.81	6.06	5.00	2.06	0.38	9.06	8	1 ¹ / ₈	1.25	+06	8.25	152
2 ⁹ / ₁₆	2.59	12.81	±0.06	0.12	5.94	3.12	6.81	5.69	2.31	0.38	10.31	8	1 ¹ / ₄	1.38	+06	9.25	153
3 ¹ / ₁₆	3.09	14.06	±0.06	0.12	6.75	3.38	7.56	6.31	2.50	0.38	11.31	8	1 ³ / ₈	1.50	+06	10.00	154
4 ¹ / ₁₆	4.09	17.56	±0.06	0.12	8.62	4.19	9.56	8.12	2.88	0.38	14.06	8	1 ³ / ₄	1.88	+09	12.25	155
7 ¹ / ₁₆	7.09	25.81	±0.12	0.25	13.88	6.50	15.19	13.31	3.81	0.62	21.81	16	2	2.12	+09	17.50	156
9	9.03	31.69	±0.12	0.25	17.38	8.06	18.94	16.88	4.25	1.00	27.00	16	2 ¹ / ₂	2.62	+09	22.38	157
11	11.03	34.75	±0.12	0.25	19.88	8.81	22.31	20.00	4.06	1.00	29.50	16	2 ³ / ₄	2.88	+09	23.75	158
13 ⁵ / ₁₆	13.66	45.75	±0.12	0.25	24.19	11.50	27.31	24.75	5.25	1.00	40.00	20	3	3.12	+12	30.00	159

GENERAL NOTES: Dimensions are in inches. Minimum Bolt Hole Tolerance is - 0.02"

TYPE 6BX WELDING NECK FLANGES FOR 10 000 psi RATED WORKING PRESSURE

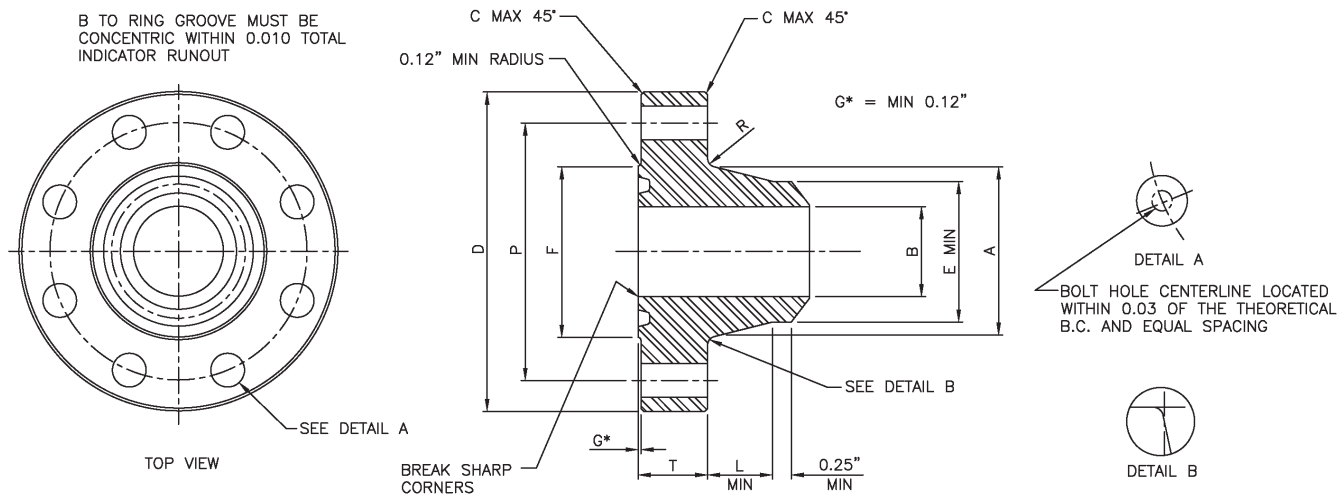

HUB AND FLANGE DIMENSIONS

Nominal Size and Bore of Flange	Maximum Bore	Outside Diameter of Flange	Tolerance	Maximum Chamfer	Diameter of Raised Face	Total Thickness of Flange	Large Diameter of Hub	Small Diameter of Hub	Length of Hub	Radius of Hub	Diameter of Bolt Circle	Number of Bolts	Diameter of Bolts	Diameter of Bolt Holes	Bolt Hole Tolerance (see note)	Minimum Length of Stud Bolts	Ring number
B	D	D	C	F	T	A	E	L	R	P							BX
10 000 psi																	
1 ³ / ₁₆	1.84	7.38	±0.06	0.12	4.12	1.66	3.50	2.56	1.91	0.38	5.75	8	¾	.88	+0.06	5.00	151
2 ¹ / ₁₆	2.09	7.88	±0.06	0.12	4.38	1.73	3.94	2.94	2.03	0.38	6.25	8	¾	.88	+0.06	5.25	152
2 ⁹ / ₁₆	2.59	9.12	±0.06	0.12	5.19	2.02	4.75	3.62	2.25	0.38	7.25	8	7/8	1.00	+0.06	6.00	153
3 ¹ / ₁₆	3.09	10.62	±0.06	0.12	6.00	2.30	5.59	4.34	2.50	0.38	8.50	8	1	1.12	+0.06	6.75	154
4 ¹ / ₁₆	4.09	12.44	±0.06	0.12	7.28	2.77	7.19	5.75	2.88	0.38	10.19	8	1 ¹ / ₈	1.25	+0.06	8.00	155
5 ¹ / ₈	5.16	14.06	±0.06	0.12	8.69	3.13	8.81	7.19	3.19	0.38	11.81	12	1 ¹ / ₈	1.25	+0.06	8.75	169
7 ¹ / ₁₆	7.09	18.88	±0.12	0.25	11.88	4.06	11.88	10.00	3.75	0.62	15.88	12	1 ¹ / ₂	1.62	+0.09	11.25	156
9	9.03	21.75	±0.12	0.25	14.12	4.88	14.75	12.88	3.69	0.62	18.75	16	1 ¹ / ₂	1.62	+0.09	13.00	157
11	11.03	25.75	±0.12	0.25	16.88	5.56	17.75	15.75	4.06	0.62	22.25	16	1 ³ / ₄	1.88	+0.09	15.00	158
13 ³ / ₈	13.66	30.25	±0.12	0.25	20.38	6.62	21.75	19.50	4.50	0.62	26.50	20	1 ⁷ / ₈	2.00	+0.09	17.25	159
16 ³ / ₄	16.78	34.31	±0.12	0.25	22.69	6.62	25.81	23.69	3.00	0.75	30.56	24	1 ⁷ / ₈	2.00	+0.09	17.50	162

GENERAL NOTES: Dimensions are in inches. Minimum Bolt Hole Tolerance is - 0.02"
Available with a transition from 4130 to LF2

TYPE 6BX WELDING NECK FLANGES FOR 15 000 and 20 000 psi RATED WORKING PRESSURE

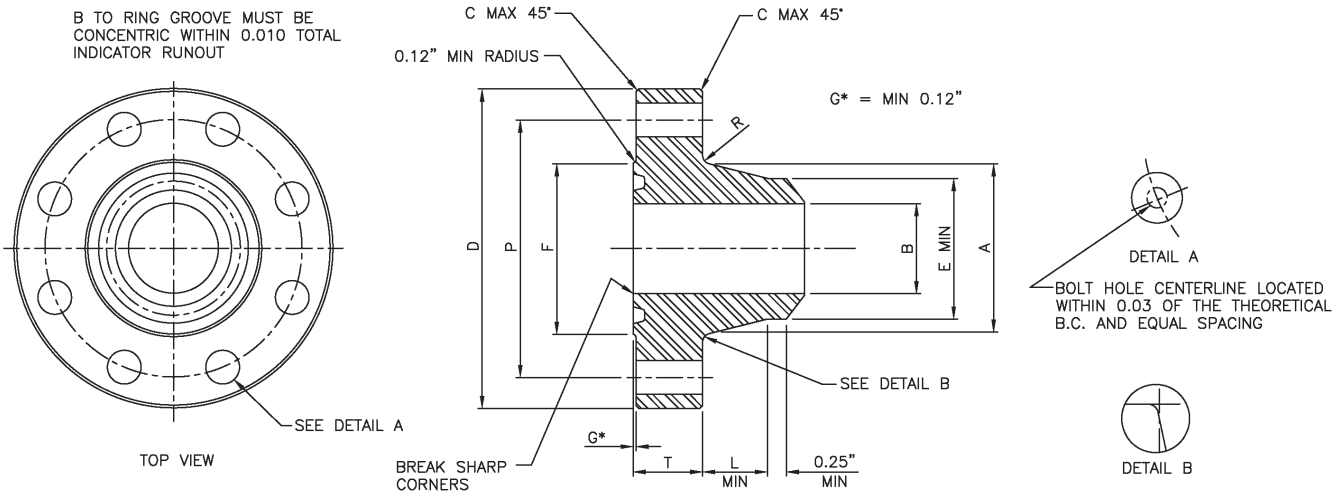

HUB AND FLANGE DIMENSIONS

Nominal Size and Bore of Flange	Maximum Bore	Outside Diameter of Flange	Tolerance	Maximum Chamfer	Diameter of Raised Face	Total Thickness of Flange	Large Diameter of Hub	Small Diameter of Hub	Length of Hub	Radius of Hub	Diameter of Bolt Circle	Number of Bolts	Diameter of Bolts	Diameter of Bolt Holes	Bolt Hole Tolerance (see note)	Minimum Length of Stud Bolts	Ring number
	B	D	D	C	F	T	A	E	L	R	P						BX
15 000 psi																	
1 ³ / ₁₆	1.84	8.19	±0.06	0.12	4.19	1.78	3.84	2.81	1.88	0.38	6.31	8	7/8	1.00	+0.06	5.50	151
2 ¹ / ₁₆	2.09	8.75	±0.06	0.12	4.50	2.00	4.38	3.25	2.12	0.38	6.88	8	7/8	1.00	+0.06	6.00	152
2 ⁹ / ₁₆	2.59	10.00	±0.06	0.12	5.25	2.25	5.06	3.94	2.25	0.38	7.88	8	1	1.12	+0.06	6.75	153
3 ¹ / ₁₆	3.09	11.31	±0.06	0.12	6.06	2.53	6.06	4.81	2.50	0.38	9.06	8	1 ¹ / ₈	1.25	+0.06	7.50	154
4 ¹ / ₁₆	4.09	14.19	±0.06	0.12	7.62	3.09	7.69	6.25	2.88	0.38	11.44	8	1 ³ / ₈	1.50	+0.06	9.25	155
5 ¹ / ₈	5.16	16.50	±0.06	0.12	8.88	3.88	9.62	7.88	3.22	0.62	13.50	12	1 ¹ / ₂	1.62	+0.09	11.50	169
7 ¹ / ₁₆	7.09	19.88	±0.12	0.25	12.00	4.69	12.81	10.88	3.62	0.62	16.88	16	1 ¹ / ₂	1.62	+0.09	12.75	156
20 000 psi																	
1 ³ / ₁₆	1.84	10.12	±0.06	0.12	4.62	2.50	5.25	4.31	1.94	0.38	8.00	8	1	1.12	+0.06	7.50	151
2 ¹ / ₁₆	2.09	11.31	±0.06	0.12	5.19	2.81	6.06	5.00	2.06	0.38	9.06	8	1 ¹ / ₈	1.25	+0.06	8.25	152
2 ⁹ / ₁₆	2.59	12.81	±0.06	0.12	5.94	3.12	6.81	5.69	2.31	0.38	10.31	8	1 ¹ / ₄	1.38	+0.06	9.25	153
3 ¹ / ₁₆	3.09	14.06	±0.06	0.12	6.75	3.38	7.56	6.31	2.50	0.38	11.31	8	1 ³ / ₈	1.50	+0.06	10.00	154
4 ¹ / ₁₆	4.09	17.56	±0.06	0.12	8.62	4.19	9.56	8.12	2.88	0.38	14.06	8	1 ³ / ₄	1.88	+0.09	12.25	155
7 ¹ / ₁₆	7.09	25.81	±0.12	0.25	13.88	6.50	15.19	13.31	3.81	0.62	21.81	16	2	2.12	+0.09	17.50	156

GENERAL NOTES: Dimensions are in inches. Minimum Bolt Hole Tolerance is - 0.02"

Available with a transition from 4130 to LF2

TYPE 6BX BLIND & TEST FLANGES FOR 10 000 and 15 000 psi RATED WORKING PRESSURE

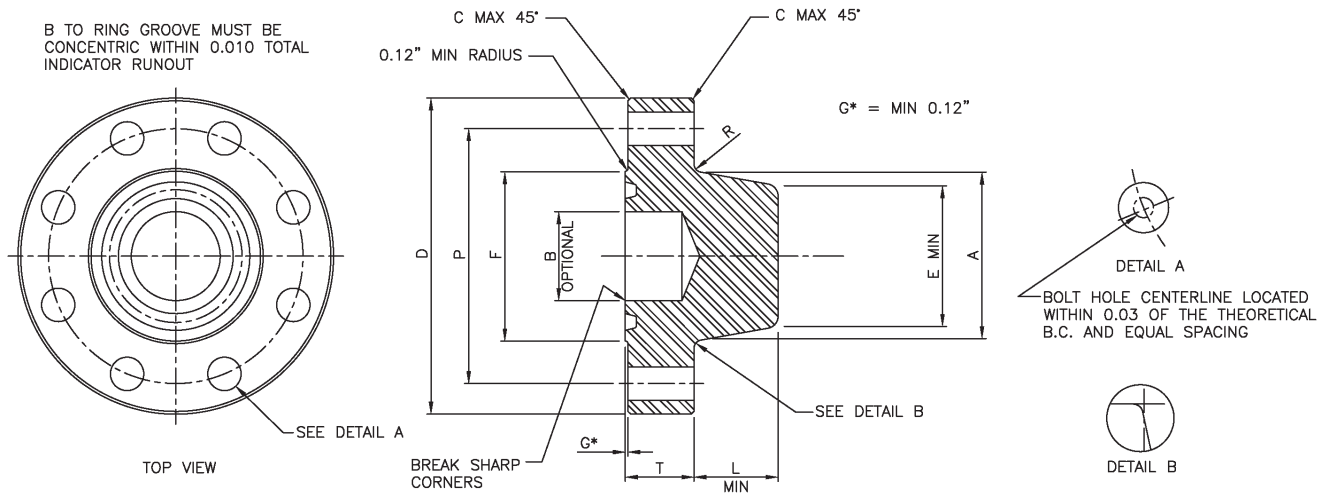

HUB AND FLANGE DIMENSIONS

Nominal Size and Bore of Flange	Maximum Bore	Outside Diameter of Flange	Tolerance	Maximum Chamfer	Diameter of Raised Face	Total Thickness of Flange	Large Diameter of Hub	Small Diameter of Hub	Length of Hub	Radius of Hub	Diameter of Bolt Circle	Number of Bolts	Diameter of Bolts	Diameter of Bolt Holes	Bolt Hole Tolerance (see note)	Minimum Length of Stud Bolts	Ring number
B	D	D	C	F	T	A	E	L	R	P							BX
10 000 psi																	
1 ³ / ₁₆	1.84	7.38	±0.06	0.12	4.12	1.66	3.50	2.56	1.91	0.38	5.75	8	3/4	.88	+0.06	5.00	151
2 ¹ / ₁₆	2.09	7.88	±0.06	0.12	4.38	1.73	3.94	2.94	2.03	0.38	6.25	8	3/4	.88	+0.06	5.25	152
2 ⁹ / ₁₆	2.59	9.12	±0.06	0.12	5.19	2.02	4.75	3.62	2.25	0.38	7.25	8	7/8	1.00	+0.06	6.00	153
3 ¹ / ₁₆	3.09	10.62	±0.06	0.12	6.00	2.30	5.59	4.34	2.50	0.38	8.50	8	1	1.12	+0.06	6.75	154
4 ¹ / ₁₆	4.09	12.44	±0.06	0.12	7.28	2.77	7.19	5.75	2.88	0.38	10.19	8	1 ¹ / ₈	1.25	+0.06	8.00	155
15 000 psi																	
1 ³ / ₁₆	1.84	8.19	±0.06	0.12	4.19	1.78	3.84	2.81	1.88	0.38	6.31	8	7/8	1.00	+0.06	5.50	151
2 ¹ / ₁₆	2.09	8.75	±0.06	0.12	4.50	2.00	4.38	3.25	2.12	0.38	6.88	8	7/8	1.00	+0.06	6.00	152
2 ⁹ / ₁₆	2.59	10.00	±0.06	0.12	5.25	2.25	5.06	3.94	2.25	0.38	7.88	8	1	1.12	+0.06	6.75	153
3 ¹ / ₁₆	3.09	11.31	±0.06	0.12	6.06	2.53	6.06	4.81	2.50	0.38	9.06	8	1 ¹ / ₈	1.25	+0.06	7.50	154
4 ¹ / ₁₆	4.09	14.19	±0.06	0.12	7.62	3.09	7.69	6.25	2.88	0.38	11.44	8	1 ³ / ₈	1.50	+0.06	9.25	155

GENERAL NOTES: Dimensions are in inches. Minimum Bolt Hole Tolerance is - 0.02"

TYPE 6BX BLIND & TEST FLANGES FOR 20 000 psi RATED WORKING PRESSURE

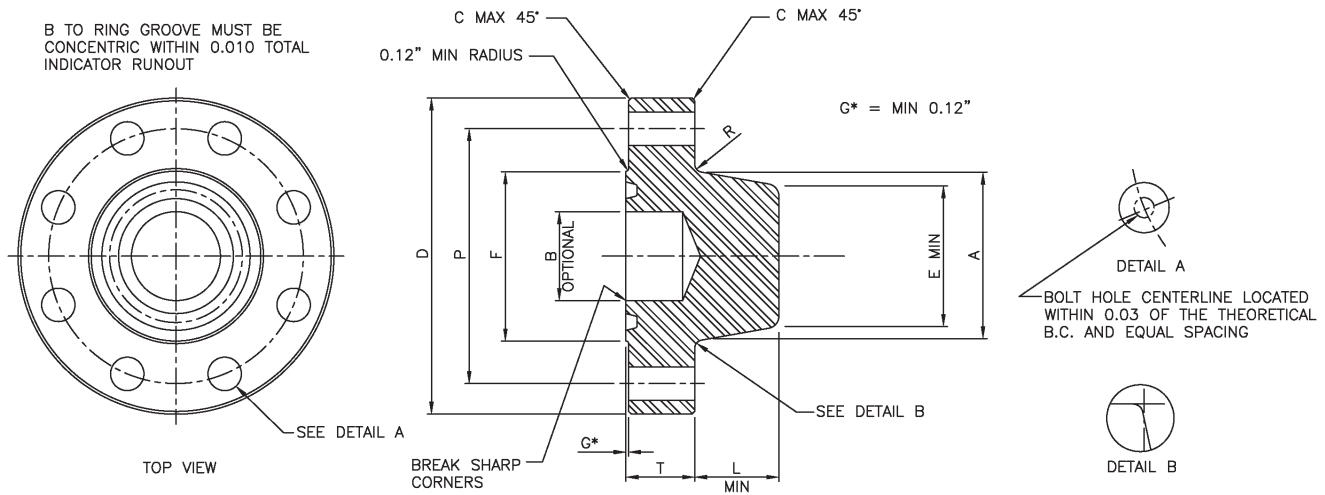

HUB AND FLANGE DIMENSIONS

Nominal Size and Bore of Flange	Maximum Bore	Outside Diameter of Flange	Tolerance	Maximum Chamfer	Diameter of Raised Face	Total Thickness of Flange	Large Diameter of Hub	Small Diameter of Hub	Length of Hub	Radius of Hub	Diameter of Bolt Circle	Number of Bolts	Diameter of Bolts	Diameter of Bolt Holes	Bolt Hole Tolerance (see note)	Minimum Length of Stud Bolts	Ring number
	B	D	D	D	C	F	T	A	E	L	R	P					BX
20 000 psi																	
1 ³ / ₁₆	1.84	10.12	±0.06	0.12	4.62	2.50	5.25	4.31	1.94	0.38	8.00	8	1	1.12	+06	7.50	151
2 ¹ / ₁₆	2.09	11.31	±0.06	0.12	5.19	2.81	6.06	5.00	2.06	0.38	9.06	8	1 ¹ / ₈	1.25	+06	8.25	152
2 ⁹ / ₁₆	2.59	12.81	±0.06	0.12	5.94	3.12	6.81	5.69	2.31	0.38	10.31	8	1 ¹ / ₄	1.38	+06	9.25	153
3 ¹ / ₁₆	3.09	14.06	±0.06	0.12	6.75	3.38	7.56	6.31	2.50	0.38	11.31	8	1 ³ / ₈	1.50	+06	10.00	154
4 ¹ / ₁₆	4.09	17.56	±0.06	0.12	8.62	4.19	9.56	8.12	2.88	0.38	14.06	8	1 ³ / ₄	1.88	+09	12.25	155

GENERAL NOTES: Dimensions are in inches. Minimum Bolt Hole Tolerance is - 0.02"